

CITY OF SPRING LAKE PARK
1301 81ST AVENUE N.E.
AGENDA
MONDAY, APRIL 20, 2015
7:00 P.M.

1. CALL TO ORDER
2. ROLL CALL
3. PLEDGE OF ALLEGIANCE
4. ADDITIONS OR CORRECTIONS TO AGENDA
5. CONSENT AGENDA:
 - A. Approval of Minutes – April 6, 2015
 - B. Disbursements:
 1. General Operations Disbursement Claim No. 15-05 – \$356,172.06
 2. Liquor Fund Disbursement Claim No. 15-06 - \$187,323.64
 - C. Contractor’s Licenses
 - D. Sign Permit
 - E. Correspondence
6. DISCUSSION FROM THE FLOOR
7. PRESENTATIONS:
 - A. Mark Voight, Spring Lake Park High School
8. POLICE REPORT
9. PARKS AND RECREATION REPORT
10. PETITIONS, REQUESTS AND COMMUNICATIONS
 - A. Unfit for Home Occupation Appeal – 1547 82nd Avenue
11. ORDINANCES AND RESOLUTIONS:
 - A. Interim Ordinance on Joint Parking Facilities
 - B. Tobacco Ordinance Update
 - C. Lot Line Adjustment – 8201 Central Avenue NE
12. NEW BUSINESS:
 - A. Authorization to Hire Lead Maintenance Worker
 - B. Third Amendment to Sprint Lease Agreement
13. ENGINEER’S REPORT
14. ATTORNEY’S REPORT
15. BEYOND THE YELLOW RIBBON REPORT
16. OTHER
 - A. Administrator Reports
 - B. Recycling Day – April 25 from 9:00 AM to 1:00 PM, SLP City Hall
17. ADJOURN

**SEE REVERSE SIDE FOR RULES FOR PUBLIC HEARING
AND DISCUSSION FROM THE FLOOR**

RULES FOR PUBLIC HEARINGS AND DISCUSSION FROM THE FLOOR

DISCUSSION FROM THE FLOOR

**Limited to 5 minutes per person to state their concern.

**Action: Council direction to staff for resolution or take this matter under advisement for action at the next regularly scheduled meeting.

PUBLIC HEARINGS

Advise audience that the purpose of the public hearing is to receive citizen input on the proposal to (name of project). (This is not a time to debate the issue.)

The following format will be used to conduct the hearing:

** The presenter will have a maximum of 10 minutes to explain the project as proposed.

** Councilmembers will have an opportunity to ask questions or comment on the proposal.

** Citizens will then have an opportunity to ask questions and/or comment on the project. Those wishing to comment are asked to limit their comments to 3 minutes, except in cases where there is a spokesperson representing a group wishing to have their collective opinions voiced. The spokesperson should identify the audience group her/she is representing and may have a maximum of 10 minutes to express the views of the group.

**People wishing to comment are asked to state any new facts they may have within the 3 minutes allotted. Please be specific and to the point.

** Everyone will be given the opportunity to express their agreement or disagreement even if they have no new points to make. (This is not a time to debate the issue.)

** People wishing to speak twice will be given 2 minutes to comment on any new facts brought forward since the last time they spoke.

Following public input, the Council will have a second opportunity to ask questions of the presenter and/or citizens.

The public hearing will then be adjourned with the Council taking the matter under advisement until the next regularly scheduled Council meeting. At the next regular meeting, the Council will debate the issue, if necessary, state their positions and make a decision. NO further public input will be received at that time.

OFFICIAL PROCEEDINGS

Pursuant to due call and notice thereof, the regularly scheduled meeting of the Spring Lake Park City Council was held on April 6, 2015 at the Spring Lake Park Community Center, 1301 81st Avenue N. E., at 7:00 P.M.

1. Call to Order

Mayor Hansen called the meeting to order at 7:00 P.M.

2. Roll Call

Members Present: Councilmembers Nash, Nelson, Wendling and Mayor Hansen

Members Absent: Councilmember Mason

Staff Present: Police Chief Ebeltoft; Public Works Director Randall; Building Official Brainard; Attorney Carson; Engineer Gravel; Park and Recreation Director Rygwall; Administrator Buchholtz and Executive Assistant Gooden

Visitors: Olivia Koester, ABC Newspaper

3. Pledge of Allegiance

4. Additions or Corrections to Agenda - None

5. Discussion From The Floor - None

6. Consent Agenda:

Mayor Hansen reviewed the following Consent Agenda items:

- A. Approval of Minutes – March 2, 2015
- B. Approval of Minutes- March 16, 2015
- C. Application for Exempt Permit – Alzheimer’s Association Minnesota-North Dakota
April 18, 2015 at Pov’s 65
- D. Approval of Animal Impound Services Agreement – Hillcrest Animal Hospital
- E. Acceptance of Retirement – Steve Coyle
- F. Acceptance of Resignation – Stacey Granson
- G. Contractor’s License
- H. Correspondence

Councilmember Wendling inquired on Item D about whether the contract includes the picking up of animals in the City by Hillcrest Animal Hospital. Chief Ebeltoft stated that the picking up of the animals is not included however; the Police Department will have 24-hour access to the facility.

MOTION BY COUNCILMEMBER NASH APPROVING THE CONSENT AGENDA.

ROLL CALL VOTE: ALL AYES. MOTION CARRIED.

7. Public Works Report

Public Works Director Randall reported that the Public Works Department plowed one time in the month of March and continued to maintain the skating rinks until March 6th. He reported the city crews have been busy raking and cleaning the parks including the ball fields and fence lines and continue to work on the former Cemstone building. He stated that the patching of potholes and reclaiming of asphalt will begin in early May.

8. Code Enforcement Report

Building Official Brainard reported that he attended the Council meetings on March 2nd and March 16th; the North Suburban Code Official meeting at City of Coon Rapids on March 10th; a meeting with Substance Church Architects on March 2nd; the 2012 IFC & IBC transition conference in Vadnais Heights March 26th and March 27th; and the North Suburban Building Officials Meeting at Shoreview City Hall on March 31st.

Mr. Brainard stated that in March 2015, 11 building permits were issued compared to eight in 2014. He reported that 10 mechanical permits were issued in March compared to six in 2014. He reported that six plumbing permits were issued in March 2015 compared to six in March 2014. He noted that one fire suppression permit was issued in March.

Mr. Brainard reported that the March 2015 vacancy listing shows that there are 22 vacant/foreclosed residential properties currently posted and/or soon posted by the Code Enforcement Department, which is down three from March 2014. There is one vacant/foreclosed commercial property, which is the down one from March 2014; 17 residential properties currently occupied and ready for Sheriff sale, which is down one from March 2014. He reported that 11 Administrative Tickets and four violation notices were issued in March by the Code Enforcement Department.

Mr. Brainard provided a handout on barbecues and open flames on balconies and patios for multi-family dwellings. He stated that under the Minnesota State Fire Code Appendix H, open flame barbecues on patios and balconies are not permitted.

9. Resolutions and/or Ordinances

A. Ordinance 412 Amending Chapter 49 Relating to Health and Safety; Nuisances-Unsolicited Written Materials

Administrator Buchholtz reported at the March 16, 2015 Council meeting, the City Council reviewed a draft ordinance related to the distribution of unsolicited written materials within the City. He stated that the City has received complaints from residents relating to the distribution of unsolicited written materials on their property. Administrator Buchholtz reported that the objections related to the placement of the materials in driveways of occupied and unoccupied properties alike, providing the appearance of litter which detracts from the aesthetics of the neighborhood. He stated that the placement of these materials in the driveways during the winter months can cause problems with snow removal or damage to snow removal equipment, as the materials can be buried in a subsequent snowfall.

Administrator Buchholtz stated that Ordinance 412 would create a new section in the City's nuisance code relating to unsolicited written materials. He stated the proposed ordinance would require a distributor of these materials to place the unsolicited written materials 1) in a distribution box; 2) on a porch nearest the front door; 3) in a manner where they are securely attached to the front door; 4) through a mail slot for the principal building; 5) between the screen door and the interior front door; or 6) personally with occupant of the premises.

He stated the proposed ordinance would also preserve the occupants right to restrict entry to the occupant’s premises and it does not apply to the United States Postal Service.

Administrator Buchholtz stated that it is important to note that the proposed ordinance does not prohibit the placement of unsolicited written materials on a person’s property; it only specifies where the unsolicited written materials must be placed.

Administrator Buchholtz stated that the City Council, at its March 16, 2015 meeting, recommended that the proposed ordinance be drafted and placed on the April 6, 2015 agenda. He stated the City Council recommended approval of the proposed ordinance at that time.

MOTION BY COUNCILMEMBER NASH TO APPROVE ORDINANCE NO. 412 AMENDING CHAPTER 94 OF THE SPRING LAKE PARK CODE OF ORDINANCE RELATING TO HEALTH AND SAFETY; NUISANCES. ROLL CALL VOTE: ALL AYES. MOTION CARRIED.

10. New Business

A. Authorization to Purchase 2015 Squad Car

Chief Ebeltoft stated that the 2015 State Bid Contract for police vehicles have been awarded to listed dealerships.

<u>Dealership</u>	<u>Location</u>	<u>State Bid Contract</u>	<u>Pricing</u>
Ranger Chevrolet (Chevy/Ford)	Hibbing, MN	#83064 (Ford) (Chevy)	\$27,003.00 \$28,061.36
Nelson Auto Center (Dodge)	Fergus Falls, MN	#89303	\$26,587.71

Chief Ebeltoft reported that after research, consideration and time, it was determined that the 2015 Dodge Charger AWD will best fit the police department needs and finances.

Chief Ebeltoft reported that as part of his research on State Bid Contracts; it was found that Dodge of Burnsville has a State Bid Contract. He stated that, the City of Spring Lake Park can purchase the same 2015 Dodge Charger AWD for \$25,798.00, with a savings of \$789.71 from Dodge of Burnsville over the State Bid contract price offered by Nelson Auto Center.

Chief Ebeltoft stated that he is seeking Council approval with placing an order for a 2015 Dodge Charger AWD from Dodge of Burnsville in the amount of \$25,798. He noted this purchase will come in under budget, of the 2015 budgeted funds of \$33,075, for a savings of \$7,277.

Councilmember Nelson inquired if this vehicle purchase is part of the vehicle rotation process or if it is replacing the vehicle damaged earlier in the year. Chief Ebeltoft stated that this new vehicle is part of the replacement rotation.

MOTION BY COUNCILMEMBER NELSON TO APPROVE PURCHASE OF 2015 SQUAD CAR PURCHASE IN THE AMOUNT OF \$25,798.00. ROLL CALL VOTE: ALL AYES. MOTION CARRIED.

B. Authorize Authority to Advertise Position of Police Receptionist

Chief Ebeltoft reported that with resignation of the current "Police Receptionist" on March 23, 2015, he is requesting to advertise for the position of Police Receptionist (Part-time), accept applications and conduct interviews to determine a top candidate for the position.

Chief Ebeltoft stated that once a top candidate has been identified and all necessary requirements/checks have been met, the name of the top candidate would be presented to the Mayor and City Council for approval.

Chief Ebeltoft stated that he is seeking authorization for this process to minimize the amount of time that the police department administrative staff will be short staffed and to maximize the ability to provide the citizens of the community with the administrative staff police services that they are accustomed to and expect.

MOTION MADE BY MAYOR HANSEN TO APPROVE AUTHORIZATION TO POST POSITION OF POLICE RECEPTIONIST-PART TIME AND INTERVIEW CANDIDATES. ROLL CALL VOTE: ALL AYES. MOTION CARRIED.

C. Authorize Authority to Advertise Public Works Maintenance Worker

Administrator Buchholtz reported that the City of Spring Lake Park has received notice of retirement from Steve Coyle, Lead Maintenance Worker with his last of employment with the City on April 15, 2015. He stated that Steve first started with the City on January 1, 1989 as a Maintenance Worker and was promoted to the newly created Lead Maintenance Worker position on November 5, 2001. Administrator Buchholtz expressed his appreciation to Mr. Coyle for his many contributions during his time with the City and wish Mr. Coyle nothing but the best as he enters a well-deserved retirement.

Administrator Buchholtz stated that City staff posted the opening for the Lead Maintenance Worker position internally. He stated that the City received three applications for the position. He reported that Public Works Director Randall and Administrator Buchholtz will interview the three applicants on Tuesday, April 7, 2015. He stated that staff anticipates making a recommendation on the Lead Maintenance Worker position to the City Council at its April 20, 2015 meeting. He noted that the promotion will result in a vacancy in the public works staff that will need to be filled.

Administrator Buchholtz stated that staff is seeking authorization to advertise for the position of Public Works Maintenance Worker, accept and score applications and conduct interviews to determine a finalist to present to the City Council for approval.

Councilmember Nelson commented on what a dedicated employee Coyle has been to the City and he commends him on the pride he took in maintaining the parks.

MOTION BY MAYOR HANSEN TO AUTHORIZE AUTHORITY TO ADVERTISE PUBLIC WORKS MAINTENANCE WORKER POSITION. ROLL CALL VOTE: ALL AYES. MOTION CARRIED.

D. Authorize Bidding and Approve Plans for Lift Station No. 1 – Reconstruction

Engineer Gravel reported that the next step in the Sanitary Sewer Lift Station No. 1 Reconstruction process is to approve construction plans and specifications for the site work and installation of the pre-ordered materials. He stated that at this time, staff is requesting that the City Council approve construction plans and authorize bidding for the Lift Station No. 1 Reconstruction project.

Engineer Gravel provided a summary of the estimated total project costs with the total estimated project cost of \$950,000. He stated that bids would be opened on May 11, 2015 and he feels the project bids will be at the projected cost.

MOTION MY MAYOR HANSEN TO AUTHORIZE BIDDING AND APPROVE RECONSTRUCTION PLANS FOR LIFT STATION NO. 1. ROLL CALL VOTE: ALL AYES. MOTION CARRIED.

E. Award 2015 Seal Coat Project to Pearson Brothers, Inc.

Engineer Gravel reported that quotes were received for the 2015 Seal Coat Project on March 31, 2015. He stated that quotes were requested from four contractors and two quotes were received. He provided a summary of the results of the two quotes received:

	<u>Contractor</u>	<u>Base Quote</u>
Low	Pearson Brothers Inc.	\$ 87,649.15
#2	Allied Blacktop Company	\$ 90,282.00

Engineer Gravel reported the low quote on the project was received from Pearson Brothers Inc. with a total quote amount of \$87,649.15. He stated that this compares to the Engineer's Opinion of Probable Cost of \$80,000. He stated they have been reviewed and found to be in order.

Engineer Gravel stated that if the City Council wishes to award the project to the low bidder, then Pearson Brothers Inc. should be awarded the project.

Councilmember Nelson inquired if the City has worked with Pearson Brothers Inc. has worked in the City in the past. Mr. Gravel answered affirmatively and added that they will be working on the City of Blaine project.

MOTION BY COUNCILMEMBER NELSON TO AWARD 2015 SEAL COAT PROJECT TO PEARSON BROTHERS INC. IN THE AMOUNT OF \$87,649.15. ROLL CALL VOTE: ALL AYES. MOTION CARRIED.

F. Authorize Authority to Enter Joint Powers Agreement with City of Blaine for Seal Coating of Sanburnol Drive Between University Service Road and Able Street

Administrator Buchholtz reported that the City's street maintenance program for 2015 calls for a seal coat of Sanburnol Drive and Elm Drive. He stated that since Sanburnol is a shared street with Blaine, the City of Spring Lake Park asked that the City of Blaine include these two streets in their annual seal coat project. He stated that in response to the request, Blaine has prepared bid documents that include Sanburnol Drive and Elm Drive. He stated that Blaine opened bids on March 31, 2015.

Administrator Buchholtz stated that this would be an addition to the \$80,000 project the City currently has out for bid. Engineer Gravel reported that Blaine opened bids and the City's share is \$8,468.94. He noted there is approximately \$153,000 in the City's Seal Coat Project Fund and that the City will collect approximately \$50,000 this year in franchise fees.

Administrator Buchholtz stated that due to the shared nature of Sanburnol Drive, the City of Blaine is seeking City of Council approval of a joint powers agreement and staff recommends the approval of the agreement.

MOTION BY COUNCILMEMBER NASH TO APPROVE JOINT POWERS AGREEMENT WITH CITY OF BLAINE FOR SEAL COATING OF SANBURNOL DRIVE BETWEEN UNIVERSITY SERVICE ROAD AND ABLE STREET. ROLL CALL VOTE: ALL AYES. MOTION CARRIED.

G. Request for Joint Council Meeting to Discuss SBM Fire Department Budget

Administrator Buchholtz reported that the City of Blaine has requested that the City Councils of Blaine, Mounds View and Spring Lake Park hold a joint meeting to discuss the 2016 SBM Fire Department budget.

Administrator Buchholtz provided dates to the Council and it was agreed that either June 9, 2015 or June 10, 2015 would be acceptable. He stated that he will follow up with Chief Zikmund.

H. Request to Schedule Workshop Session for April 13, 2015 at 6:30 PM

Administrator Buchholtz reported that staff is requesting a workshop session to discuss the updating of City ordinances including massage, tobacco and liquor ordinances. Consensus of the the Council was to schedule the workshop for Monday, April 13, 2015 at 6:30 PM at Spring Lake Park City Hall.

11. Engineer's Report

Engineer Gravel reported that bids will be received in April for the 2015 Sanitary Sewer Lining Project and bids will be received for the Lift Station No. 1 Reconstruction project on May 11, 2015. He stated that the developers on the medical building at 525 Osborne Road have stated that project is on long-term hold.

Councilmember Wendling inquired as to what the reason is for the long-term hold. Mr. Gravel stated that the reason for the hold is unknown.

12. Attorney's Report – None

13. Reports - None

14. Other

A. Administrator Reports

Administrator Buchholtz reported that the auditors have completed their fieldwork and will present a draft copy in a few months. He stated that he attended the Spring Lake Park School Task Force meeting and reported that the goal of the task force is to create a master facilities plan for the future.

15. Adjourn

MOTION BY COUNCILMEMBER NASH TO ADJOURN. VOICE VOTE: ALL AYES. MOTION CARRIED.

The meeting was adjourned at 7:35 P.M.

Attest:

Cindy Hansen, Mayor

Daniel R. Buchholtz, Administrator, Clerk/Treasurer

CITY OF SPRING LAKE PARK
 CLAIMS LIST APPROVED AND PAID
 GENERAL OPERATIONS

Date: MARCH 2015

Page: 1

Claim Res.#15-05

<u>VOUCHER</u>	<u>VENDOR</u>	<u>DESCRIPTION</u>	<u>AMOUNT</u>
57331	AT & T MOBILITY	DATA SERVICES	\$ 12.67
57332	CENTERPOINT ENERGY	MONTHLY SERVICES	\$ 2,319.62
57333	CONNEXUS ENERGY	MONTHLY SERVICES	\$ 13.03
57334	FERGUSON WATERWORKS	WATERMAIN BREAK 83RD & MONROE	\$ 1,243.20
57335	GOPHER STATE ONE-CALL INC	FEB LOCATES	\$ 39.35
57336	HOLIDAY INN	GROUP RESERVATIONS	\$ 2,468.57
57337	HOTSY EQUIPMENT OF MN	PRESSURE WASHER	\$ 6,950.90
57338	GARY KING	INSTRUCTOR	\$ 480.00
57339	MANSFIELD OIL COMPANY	FUEL	\$ 1,625.39
57340	METROPOLITAN COUNCIL	APRIL WASTEWATER CHARGES	\$ 37,834.92
57341	MINNEAPOLIS SAW	PARTS	\$ 162.22
57342	KAY OKEY	REIM FOR MILEAGE & EXPENSES	\$ 116.10
57343	SHRED-IT USA LOS ANGELES	SHREDDING SERVICES	\$ 68.01
57344	SPRING LAKE PARK LUMBER	LUMBER	\$ 421.63
57345	TWIN CITIES BMEU WEST	UBILL POSTAGE	\$ 830.00
57346	XCEL ENERGY	MONTHLY SERVICES	\$ 51.86
57347	ADVANCED GRAPHIX INC	GRAPHICS FOR 2014 CHARGER	\$ 600.00
57348	AFLAC	PAYROLL 3/7/15	\$ 46.80
57349	AMERICAN FUNDS SERVICE CO	PAYROLL 3/7/15	\$ 50.00
57350	DEARBORN NATIONAL	PAYROLL 3/7/15	\$ 489.31
57351	DELTA DENTAL	PAYROLL 3/7/15	\$ 1,428.10
57352	FIDELITY SECURITY LIFE	PAYROLL 3/7/15	\$ 51.29
57353	HEALTH PARTNERS	PAYROLL 3/7/15	\$ 10,458.03
57354	L.E.L.S.	PAYROLL 3/7/15	\$ 295.00
57355	LOCAL 49	PAYROLL 3/7/15	\$ 99.00
57356	NCPERS MINNESOTA-7750811	PAYROLL 3/7/15	\$ 48.00
57357	P.E.R.A.	PAYROLL 3/7/15	\$ 15,445.18
57358	AJJA & AUGUSTUS LAPICKIS	REFUND	\$ 71.35
57359	BATTERIES PLUS BULBS	SUPPLIES	\$ 79.98
57360	ESSENTIAL KNOWLEDGE TRAINING	INSTRUCTOR	\$ 240.50
57361	GMS INDUSTRIAL SUPPLIES INC	MECHANICS VISE	\$ 359.00
57362	JENNY GOODEN	INSTRUCTOR	\$ 180.00
57363	LOUCKS ASSOCIATES	ZONING ORDINANCE UPDATE	\$ 750.00
57364	M.R.W.A.	MEMBERSHIP DUES	\$ 250.00
57365	MARK BONESTEEL	REIM FOR CONFERENCE EXPENSES	\$ 192.62
57366	ROBERT BRANSON	REFUND	\$ 210.87
57367	SHERWIN WILLIAMS	PROSHOT 11 HANDHELD	\$ 475.00
57368	VALLEY-RICH CO., INC.	WATERMAIN BREAK 81ST & MONROE	\$ 16,434.72
57369	ZULLAL LLC	REPLACING CHECK	\$ 85.10
57370	VOID	VOID	\$ -
57371	AID ELECTRIC SERVICE, INC	PW BLDG ELECTRICAL NEEDS	\$ 9,210.45
57372	AMANDA JACKSON	REIM FOR SUPPLIES	\$ 140.57
57373	ANOKA COUNTY	JAN-FEB WIRELESS SERVICE	\$ 405.95
57374	ASPEN MILLS	UNIFORM REPLACEMENT	\$ 47.95
57375	CONNEXUS ENERGY	MONTHLY SERVICES	\$ 388.73

CITY OF SPRING LAKE PARK
CLAIMS LIST APPROVED AND PAID
GENERAL OPERATIONS

Date: MARCH 2015

Page: 2

Claim Res.#15-05

<u>VOUCHER</u>	<u>VENDOR</u>	<u>DESCRIPTION</u>	<u>AMOUNT</u>
57376	CORRPRO COMPANIES INC	ANNUAL INSPECTIONS	\$ 1,440.00
57377	DELTA DENTAL	DENTAL INSURANCE-M MALONEY	\$ 122.00
57378	DODGE OF BURNSVILLE	SERVICE VEHICLE	\$ 19.95
57379	DODGE OF BURNSVILLE	REPAIR VEHICLE	\$ 187.95
57380	G & K SERVICES	MATS	\$ 69.22
57381	GOLDEN VALLEY SUPPLY CO.	SUPPLIES	\$ 283.20
57382	HOTSY EQUIPMENT OF MN	LABOR & PARTS	\$ 455.20
57383	INSTRUMENTAL RESEARCH INC	FEB WATER TESTING	\$ 64.00
57384	J.P. COOKE CO.	PET LICENSE BOOKS & TAGS	\$ 71.55
57385	MACQUEEN EQUIPMENT INC	MOTOR HYD	\$ 770.73
57386	MANSFIELD OIL COMPANY	FUEL	\$ 781.19
57387	PERFECT 10 CAR WASH	CAR WASHES	\$ 39.84
57388	ROSEVILLE UTILITY INVOICE	MARCH I.T. SERVICES	\$ 535.96
57389	SHERWIN WILLIAMS	PAINT	\$ 1,221.08
57390	SPRING LAKE PARK LUMBER	LUMBER	\$ 131.58
57391	TOWMASTER	PARTS	\$ 171.17
57392	TWIN CITIES BMEU WEST	NEWSLETTER POSTAGE	\$ 650.00
57393	U.S.T.I.	MONTHLY EBILL FEES	\$ 16.40
57394	WASTE MANAGEMENT-BLAINE MN	FEB SERVICE	\$ 8,390.52
57395	WELLS FARGO CREDIT CARD	CREDIT CARD PURCHASES	\$ 12,873.10
57396	WIPERS AND WIPES INC	PAPER PRODUCTS	\$ 380.52
57397	ZARNOTH BRUSH WORKS INC	WAFER BROOM REFILLS	\$ 448.85
57398	ZEP MANUFACTURING	CLEANER	\$ 399.06
57399	AFLAC	PAYROLL 3/14/15	\$ 46.80
57400	AMERICAN FUNDS SERVICE CO	PAYROLL 3/14/15	\$ 50.00
57401	DEARBORN NATIONAL	PAYROLL 3/14/15	\$ 489.31
57402	DELTA DENTAL	PAYROLL 3/14/15	\$ 1,428.70
57403	FIDELITY SECURITY LIFE	PAYROLL 3/14/15	\$ 51.29
57404	HEALTH PARTNERS	PAYROLL 3/14/15	\$ 10,458.03
57405	L.E.L.S.	PAYROLL 3/14/15	\$ 235.00
57406	LOCAL 49	PAYROLL 3/14/15	\$ 99.00
57407	NCPERS MINNESOTA-7750811	PAYROLL 3/14/15	\$ 48.00
57408	P.E.R.A.	PAYROLL 3/14/15	\$ 15,551.76
57409	AID ELECTRIC SERVICE, INC	RELAMP & REPAIR POLE LIGHTS	\$ 409.17
57410	ANNICA INC	YOUTH CLASS	\$ 964.00
57411	BRAUN INTERTEC	SOIL BORING & TESTING	\$ 2,360.00
57412	DANIEL BUCHHOLTZ	REIM FOR CONFERENCE AIRFARE	\$ 547.20
57413	COORDINATED BUSINESS SYSTEMS	COPIER MAINT-ADMIN	\$ 874.48
57414	DELL MARKETING	SQUAD COMPUTERS	\$ 20,729.40
57415	ENGBERG PLUMBING INC	BALANCE OF PLUMBING WORK-PW BLDG	\$ 12,536.20
57416	GRAINGER INC	DOOR CLOSER	\$ 286.88
57417	INNOVATIVE OFFICE SOLUTIONS LLC	OFFICE SUPPLIES	\$ 336.58
57418	KIDCREATE STUDIO	YOUTH CLASS	\$ 800.00
57419	LEAGUE MN CITIES INS TRUST	PROPERTY & LIABILITY INSURANCE	\$ 75,721.77
57420	MANSFIELD OIL COMPANY	FUEL	\$ 1,583.87

CITY OF SPRING LAKE PARK
 CLAIMS LIST APPROVED AND PAID
 GENERAL OPERATIONS

Date: MARCH 2015

Page: 3

Claim Res.#15-05

<u>VOUCHER</u>	<u>VENDOR</u>	<u>DESCRIPTION</u>	<u>AMOUNT</u>
57421	MARIE LABRECHE-OLSON	REFUND	\$ 20.00
57422	MENARDS	SUPPLIES	\$ 1,272.93
57423	NASSCO INC	ITCP-CIPP NON MEMBER	\$ 995.00
57424	PETTY CASH	REIM PETTY CASH	\$ 211.30
57425	SLP FIRE DEPARTMENT	APRIL FIRE PROTECTION	\$ 15,559.38
57426	THE ROCKIN HOLLYWOODS	DEPOSIT-TOWER DAYS	\$ 1,125.00
57427	KENNETH A. TOLZMANN, SAMA	1ST QTR 2015 ASSESSING SERVICES	\$ 8,752.00
57428	VALLEY PAVING INC	2014-15 ST PRJ-PAY REQUEST #4	\$ 14,948.84
57429	WALTERS RECYCLING REFUSE SERV	MARCH SERVICE	\$ 351.16
57430	XCEL ENERGY	MONTHLY SERVICES	\$ 10,680.97
57431	ZULEY AWARDS	CITY COUNCIL NAME PLATE	\$ 15.00
57432	JOHN ANGELL	REIM FOR MILEAGE	\$ 39.38
57433	ANOKA COUNTY	RECORD NOTARY-PEGGY ANDERSON	\$ 20.00
57434	AT & T MOBILITY	DATA SERVICES	\$ 20.04
57435	BLUE TOW SERVICE	TOW & STORAGE FORFEITURE VEHICLES	\$ 780.00
57436	CENTERPOINT ENERGY	MONTHLY SERVICES	\$ 1,514.67
57437	COORDINATED BUSINESS SYSTEMS	COPIER MAINT-POLICE DEPT	\$ 498.13
57438	DODGE OF BURNSVILLE	SERVICE & REPAIR VEHICLES	\$ 3,384.50
57439	EMERGENCY AUTOMOTIVE TECH	INSTALL DOCKING CRADLE IN SQUAD	\$ 223.62
57440	G & K SERVICES	MATS	\$ 69.22
57441	INNOVATIVE OFFICE SOLUTIONS LLC	STORAGE BOXES	\$ 67.50
57442	JIFFY-JR PRODUCTS	SAFETY GLASSES, GLOVES	\$ 250.33
57443	MANSFIELD OIL COMPANY	FUEL	\$ 669.35
57444	MINNEAPOLIS SAW	SUPPLIES	\$ 66.57
57445	CITY OF MINNEAPOLIS	FEB LINCOLN PAWN TRANSACTIONS	\$ 187.20
57446	NORTH COUNTRY FORD	REPAIR VEHICLE	\$ 389.02
57447	P.E.R.A.	PAYROLL 3/29/15	\$ 99.36
57448	RICHFIELD BUS CO	BUS RENTAL	\$ 620.00
57449	RICOH USA INC	SERVICE RISO MACHINE	\$ 267.73
57450	SHRED-IT USA LOS ANGELES	SHREDDING SERVICES	\$ 67.37
57451	THE HOME DEPOT	SUPPLIES	\$ 466.67
57452	WINFIELD SOLUTIONS LLC	GRASS SEED	\$ 3,949.70
57453	XCEL ENERGY	MONTHLY SERVICES	\$ 48.64
57454	GARY KING	INSTRUCTOR	\$ 240.00
TOTAL DISBURSEMENTS			\$ 356,172.06

CITY OF SPRING LAKE PARK
 CLAIMS APPROVED AND PAID

DATE: MARCH 2015
 PAGE 1 OF 3
 CLAIMS RES: 15-06

FUND: LIQUOR OPERATIONS

<u>VOUCHER VENDOR</u>	<u>EXPLANATION</u>	<u>AMOUNT</u>
25540 DEARBORN NATIONAL	PAYROLL 2/22/15-3/7/15	\$ 74.75
25541 DELTA DENTAL	PAYROLL 2/22/15-3/7/15	\$ 103.65
25542 FIDELITY SECURITY LIFE	PAYROLL 2/22/15-3/7/15	\$ 3.13
25543 HEALTH PARTNERS	PAYROLL 2/22/15-3/7/15	\$ 745.10
25544 MN TEAMSTER	PAYROLL 2/15/15-2/28-15	\$ 49.50
25545 PERA	PAYROLL 2/15/15-2/28/15	\$ 585.43
	PAYROLL 2/22/15-3/7/15	\$ 648.43
25576 AMARA WINES	LIQUOR - WINE PURCHASE	\$ 246.50
25577 AMERICAN BOTTLING COMPANY	JUICE/MIX/POP PURCHASE	\$ 120.14
25578 BELLBOY CORPORATION	LIQUOR PURCHASE	\$ 359.05
25579 CAPITOL BEVERAGE SALES	CREDIT - BEER - JUICE/MIX/POP PURCHASE	\$ 4,971.07
25580 CENTER POINT ENERGY	GAS SERVICE	\$ 228.64
25581 CRYSTAL SPRINGS ICE	ICE PURCHASE	\$ 82.72
25582 CULLIGAN	BOTTLED WATER	\$ 26.60
25583 DAHLHEIMER BEVERAGE LLC	BEER PURCHASE	\$ 460.05
25584 ECM PUBLISHERS INC	ADVERTISING	\$ 488.25
25585 GENERAL CIGAR COMPANY	CIGAR PURCHASE	\$ 242.01
25586 HOHENSTEINS INC	BEER PURCHASE	\$ 1,015.00
25587 JJ TAYLOR COMPANIES	CREDIT - BEER PURCHASE	\$ 10,910.45
25588 JOHNSON BROTHERS LIQUOR CO	CREDIT - LIQUOR - WINE PURCHASE	\$ 16,121.59
25589 M AMUNDSON LLP	CIGARETTE - JUICE/MIX/POP PURCHASE	\$ 3,701.81
25590 MCDONALD DISTRIBUTING	BEER PURCHASE	\$ 109.20
25591 METRO NORTH CHAMBER OF COMMERCE	CONFERENCE	\$ 25.00
25592 PAUSTIS & SON'S	WINE PURCHASE	\$ 677.23
25593 PHILLIPS WINE & SPIRITS CO	LIQUOR - WINE PURCHASE	\$ 1,460.95
25594 POPP.COM	TELEPHONE SERVICE	\$ 261.64
25595 QUALITY REFRIGERATION	MAINTENANCE AGREEMENT	\$ 464.00
25596 REPUBLIC SERVICES	GARBAGE SERVICES	\$ 242.52
25597 SAASTAMOINEN, LAURA	MILEAGE REIMBURSEMENT	\$ 115.18
25598 SOUTHERN WINE & SPIRITS OF MN	LIQUOR - WINE PURCHASE	\$ 5,467.95
25599 SPRINT	CELL PHONE SERVICE	\$ 177.70
25600 STAR TRIBUNE	ADVERTISING	\$ 852.00
25601 VARNER TRANSPORTATION	FREIGHT	\$ 777.40
25602 WELLS FARGO CREDIT CARD	CREDIT CARD PAYMENT	\$ 313.93
25603 WINE COMPANY	WINE PURCHASE	\$ 639.55
25604 WINE MERCHANTS	WINE PURCHASE	\$ 487.00
25605 WIRTZ BEVERAGE MN BEER	CREDIT - BEER - LIQUOR PURCHASE	\$ 11,546.45
	JUICE/MIX/POP PURCHASE	\$ -
25606 DEARBORN NATIONAL	PAYROLL 3/8/15-3/21/15	\$ 74.75
25607 DELTA DENTAL	PAYROLL 3/8/15-3/21/15	\$ 103.65
25608 FIDELITY SECURITY LIFE	PAYROLL 3/8/15-3/21/15	\$ 3.13
25609 HEALTH PARTNERS	PAYROLL 3/8/15-3/21/15	\$ 745.10
25610 MN TEAMSTER	PAYROLL 3/1/15-3/14/15	\$ 58.50
25611 PERA	PAYROLL 3/1/15-3/14/15	\$ 643.61
	PAYROLL 3/8/15-3/21/15	\$ 648.43

CITY OF SPRING LAKE PARK
 CLAIMS APPROVED AND PAID

DATE: MARCH 2015
 PAGE 2 OF 3
 CLAIMS RES: 15-06

FUND: LIQUOR OPERATIONS

<u>VOUCHER VENDOR</u>	<u>EXPLANATION</u>	<u>AMOUNT</u>
25612 ANOKA COUNTY	2015 PROPERTY TAX	\$ 69.14
25613 CAPITOL BEVERAGE SALES	BEER PURCHASE	\$ 68.47
25614 J.C. NEWMAN CIGAR CO	CIGAR PURCHASE	\$ 228.48
25615 LEAGUE MN CITIES INS TRUST	LIQUOR LIABILITY INSURANCE	\$ 14,745.23
25616 WELLS FARGO	CASH REFILL FOR ATM	\$ 5,000.00
25617 XCEL ENERGY	ELECTRICITY SERVICE	\$ 1,530.41
25618 MDA SHAMROCK	JUICE/MIX/POP PURCHASE	\$ 178.00
25619 BELLBOY CORPORATION	LIQUOR PURCHASE	\$ 2,277.83
25620 BERNICK'S WINE	BEER PURCHASE	\$ 524.60
25621 CAPITOL BEVERAGE SALES	BEER PURCHASE	\$ 11,478.85
25622 CENTER POINT ENERGY	GAS UTILITIES	\$ 122.84
25623 CITYWIDE WINDOW SERVICES	CONTRACTUAL SERVICES	\$ 30.00
25624 CLEAR RIVER BEVERAGE COMPANY	LIQUOR PURCHASE	\$ 36.40
25625 CRYSTAL SPRINGS ICE	ICE PURCHASE	\$ 101.28
25626 DAHLHEIMER BEVERAGE LLC	CREDIT - BEER PURCHASE	\$ 2,657.19
25627 G & K SERVICES	CLEANING SUPPLIES	\$ 88.20
25628 HOHENSTEINS	BEER PURCHASE	\$ 496.50
25629 JJ TAYLOR COMPANIES	CREDIT - BEER PURCHASE	\$ 9,078.13
25630 JOHNSON BROTHERS LIQUOR CO	CREDIT - LIQUOR - WINE PURCHASE	\$ 9,939.37
25631 MIDWEST COCA-COLA BOTTLING	JUICE/MIX/POP PURCHASE	\$ 323.52
25632 MIDWESTERN SALES COMPANY	SHELF CLIPS	\$ 17.15
25633 PAUSTIS & SON'S	WINE PURCHASE	\$ 459.96
25634 PHILLIPS WINE & SPIRITS CO	LIQUOR - WINE PURCHASE	\$ 2,005.00
25635 PLAYNETWORK	CONTRACTUAL SERVICES	\$ 32.01
25636 SAM'S CLUB	CREDIT CARD PAYMENT	\$ 50.22
25637 SAPSUCKER FARMS ORGANICS	LIQUOR PURCHASE	\$ 127.20
25638 SILENT WATCHDOG	SECURITY MONITORING	\$ 60.00
25639 SOUTHERN WINE & SPIRITS OF MN	LIQUOR PURCHASE	\$ 15,796.02
25640 TRIO SUPPLY COMPANY	OPERATING SUPPLIES - JUICE/MIX/POP PU	\$ 437.66
25641 WINFIELD SOLUTIONS LLC	FERTILIZER	\$ 136.20
25642 WIRTZ BEVERAGE MINNESOTA BEER	CREDIT - BEER - LIQUOR JUICE/MIX/POP PURCHASE	\$ 9,528.22
TRANSFER TO PAYROLL	PAYROLL (3/06/15)	8,835.30
TRANSFER TO PAYROLL	PAYROLL (3/20/15)	9,246.65
	SALES TAX (Feb.)	12,946.00
	OTP Tax (Feb.)	1,592.87
	TOTAL DISBURSEMENTS	\$ 187,323.64

WHEREAS,
the City Council of the City of Spring Lake Park has considered the foregoing itemized list of disbursements; and

WHEREAS,
the City Council has determined that all disbursements, as listed, with the following exceptions:

are proper.

NOW, THEREFORE BE IT RESOLVED:
that the Council directs and approves the payment of the aforementioned disbursements this
____ day of _____, 20____.

Signed: _____
Mayor

Councilmembers:

ATTEST:

Daniel Buchholtz, Administrator/Clerk-Treasurer

City of Spring Lake Park
1301 81st Avenue NE
Spring Lake Park, MN 55432

Contractors Licenses

April 20, 2015

General Contractor

Gallas Construction

Mechanical Contractor

Genz Ryan Plumbing & Heating

Harris Companies

Riccar Heating and Air

Sign Contractor

Albrecht Sign Co.

Tree Contractor

Gosiak Tree Service, LLC

Steve's Quality Tree Service

City of Spring Lake Park
1301 81st Avenue NE
Spring Lake Park, MN 55432

Sign Permits

April 20, 2015

Advance Auto Parts

8151 University Ave

Akways Sports Barber Shop

8097 Hwy 65 #103

CITY OF SPRING LAKE PARK
1301 81ST AVENUE NE
SPRING LAKE PARK, MN 55432

SIGN PERMIT APPLICATION

DATE: 3/10/2015

NAME OF APPLICANT: Site Enhancement Services c/o Advance Auto Parts

ADDRESS OF APPLICANT: 6001 Nimitz Parkway, South Bend, IN 46628

TELEPHONE NUMBER OF APPLICANT: 855-525-6261

NAME OF BUSINESS AND LOCATION of building structure, or lot to which or upon which the sign is to be attached or erected Advance Auto Parts- 8151 University Avenue NE

New Construction: Remodel: Word Change Only:

Attach a drawing or sketch showing the position of the sign in relation to the nearest building, structures, public streets, right-of-way and property lines. Said drawing to be prepared to scale.

Attach two (2) blueprints or ink drawings of the plans and specifications and method of construction or attachment to the building or in the ground, including all dimensions. Show location of all light sources, wattage, type and color of lights and details of light shields or shades.

Attach a copy of stress sheets and calculations showing the structure is designed for dead load and wind velocity in the amount required by this and all other Ordinances of the City, if requested by the Building Inspection Department.

Name of person, firm or corporation erecting the structure: Advance Auto Parts

Installer: Top Line Advertising

Address: 11775 Justin Circle, Suite A, Maple Grove, MN 55369

Is an Electrical Permit required? Yes- Connecting to junction box provided by the GC's electrician

I, the undersigned applicant, do further make the following agreement with the City of Spring Lake Park Mn:

- 1) To authorize and direct the City of Spring Lake Park to remove and dispose of any signs and sign structures on which a Permit has been issued but which was not renewed, if the owner does not remove the same within thirty (30) days following the expiration of the Permit.
- 2) To authorize and direct the City of Spring Lake Park to remove said sign and sign structure, at the expense of the applicant, where maintenance is not furnished, but only after a hearing and after notice of sixty (60) days, specifying the maintenance required by the City.
- 3) To provide any other additional information which may be required by the Building Inspection Department.

SIGNATURE OF APPLICANT

FOR OFFICE USE ONLY:*****

FEE: \$324 + \$120 = \$444

RECEIPT NUMBER: _____

DATE OF APPROVAL: _____ DATE OF ISSUE: _____

REASON FOR DENIAL: _____

ADDITIONAL REQUIREMENTS FOR SIGN PERMIT:

SQUARE FOOTAGE OF FRONT OF BUILDING: 21,852 sq ft

SQUARE FOOTAGE OF ALL EXISTING SIGNS: 1519 sq ft

SQUARE FOOTAGE OF PROPOSED SIGN OR SIGNS: 3 building 88 sq ft x 3 = 264 sq ft | pylon 20 sq ft x 2 = 40 sq ft
304 sq ft Total

INCLUDE A DRAWING SHOWING LOCATION AND MESSAGE ON SIGN.

IF YOU ARE NOT THE OWNER OF THE PROPERTY, INCLUDE A SIGNED LETTER FROM THE OWNER GIVING PERMISSION TO ERECT THE SIGN.

NOTE: ALL APPLICATIONS ARE DUE BY NOON ON THE THURSDAY PRECEEDING THE COUNCIL MEETING.

DRAWING:

proposed
88 sq ft Building \$60 (40 sq ft)
\$48 (48 sq ft x \$1.00)

\$108 x 3 = \$324.00

pylon
20 sq ft x 2 \$60 x 2 = \$120

6556 - 30%
Existing
- 55 sq ft Asia market sign
- 40 sq ft (pylon)
1519 sq ft existing
304 sq ft proposed

4638 sq ft Remaining



- A1
 - A2
 - A3
- 30" Yellow Channel Letterset

888

432

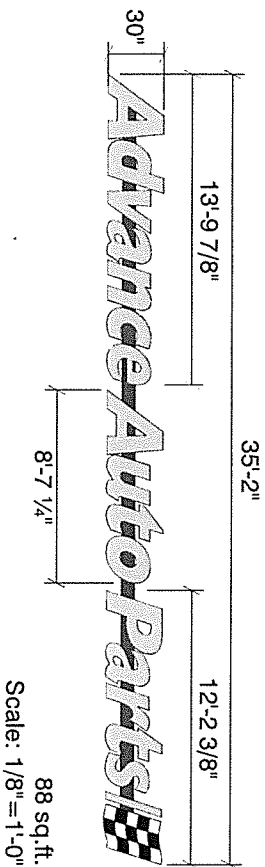

A1 A2 A3 30" Yellow Channel Letterset

POWER SUPPLY: Galcore model GECLPS3 or GECLPS4 (UL classified)
 LED UNIT: Galcore (5 per ft.)
 DISCONNECT SWITCH: 20 amp toggle safety switch, single pole
 with rubber boot (UL approved)

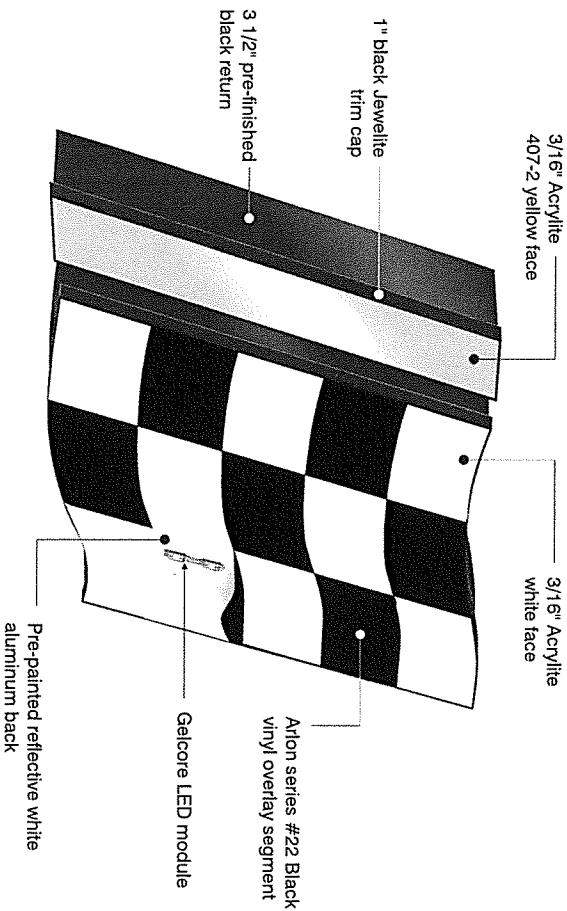
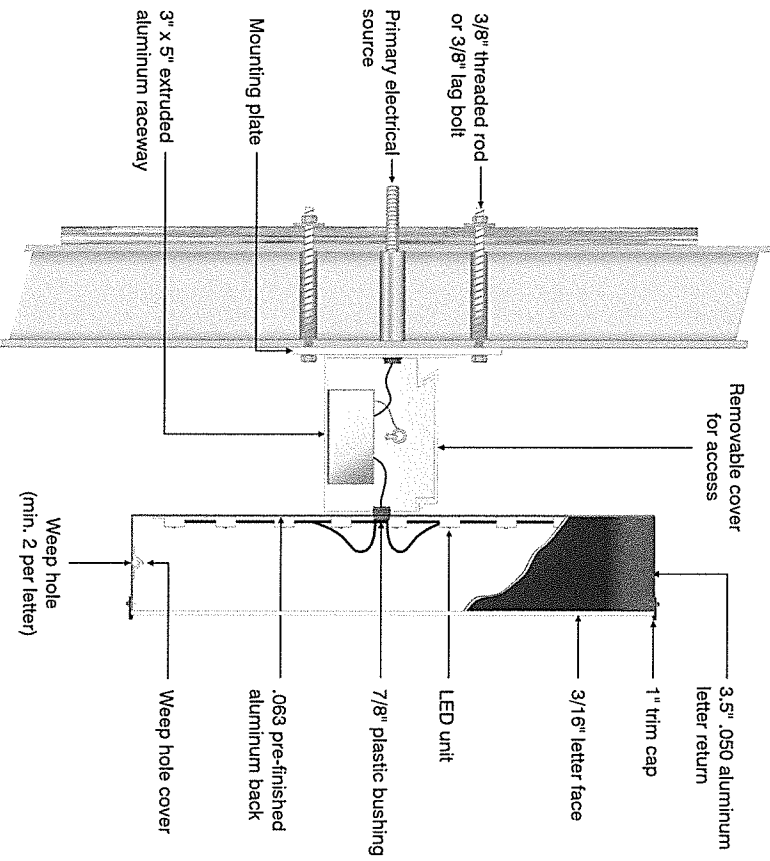
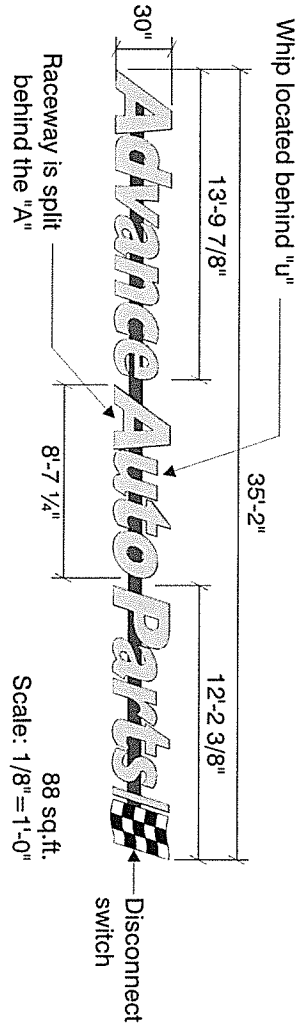

Sign components to be in strict compliance with all UL standards.



Existing Front Elevation

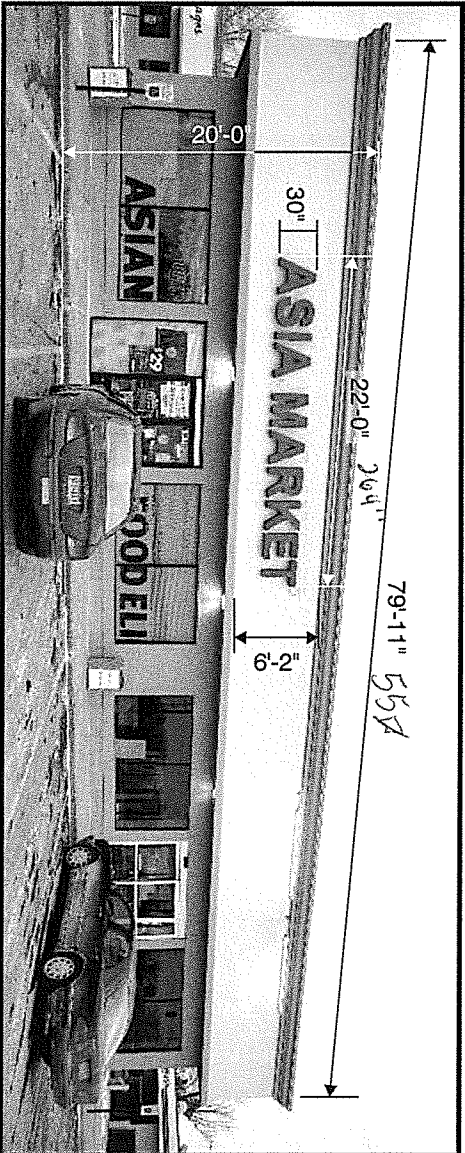

Proposed Front Elevation

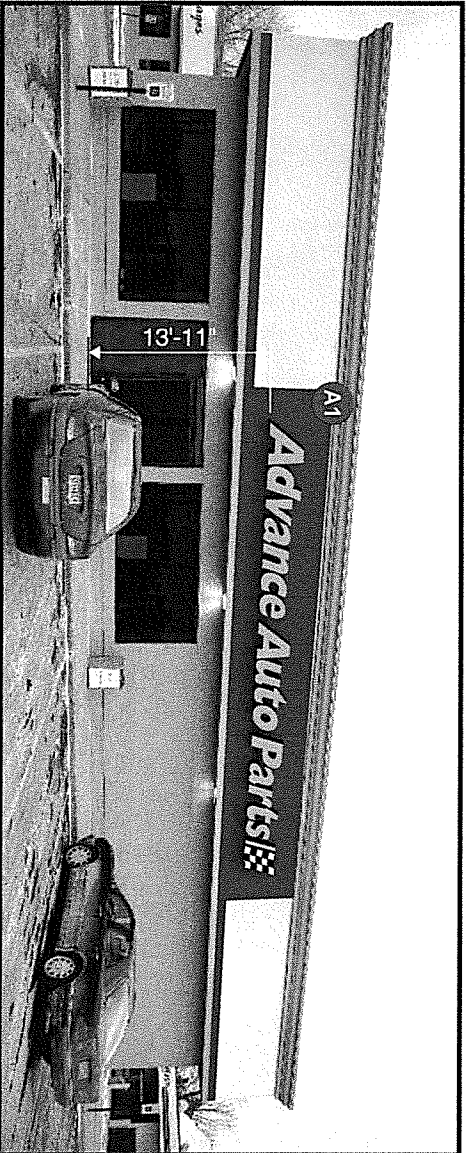

Red Background Area - Modular Red Panel System

*Signage size and placement are approximate.

Existing Right Elevation

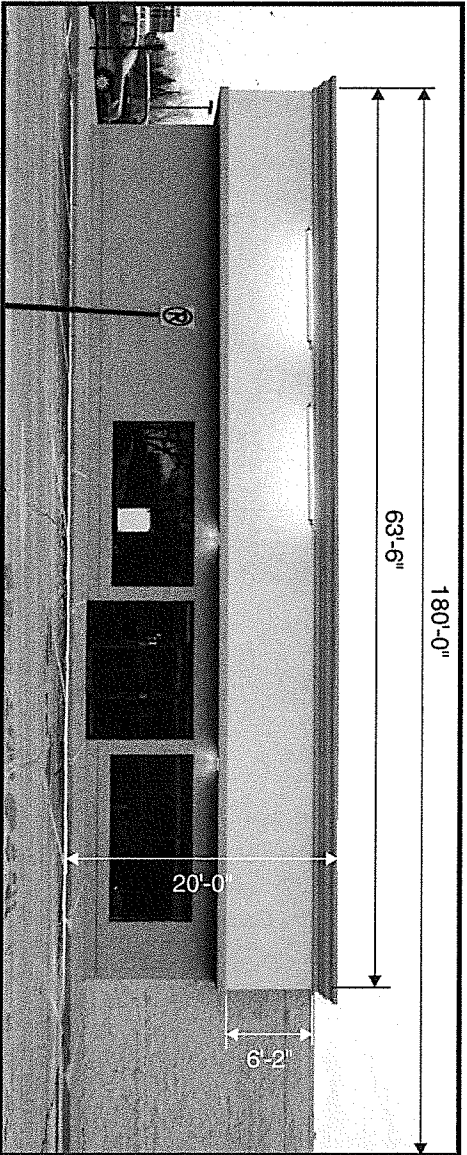

Proposed Right Elevation



Red Background Area - Modular Red Panel System

*Signage size and placement are approximate.

Existing Left Elevation

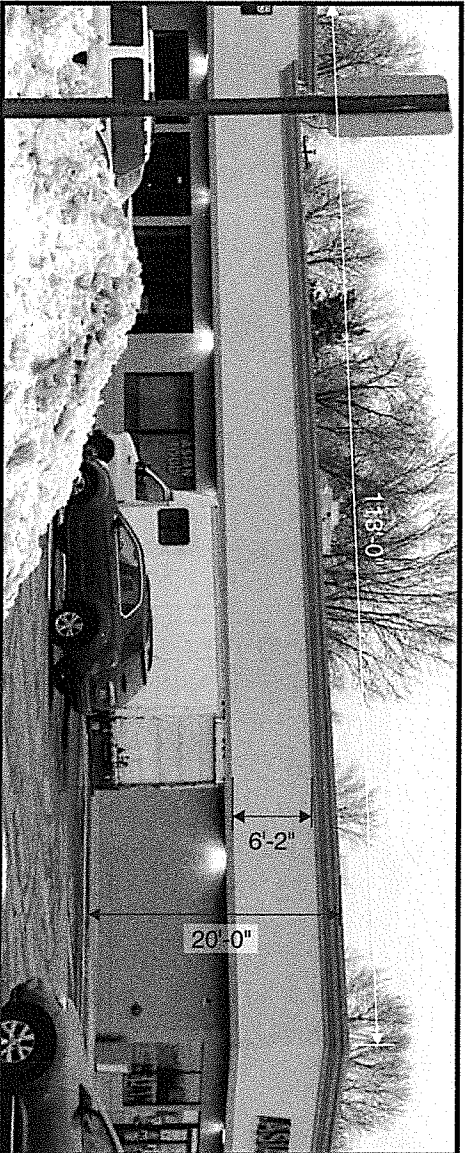

Proposed Left Elevation

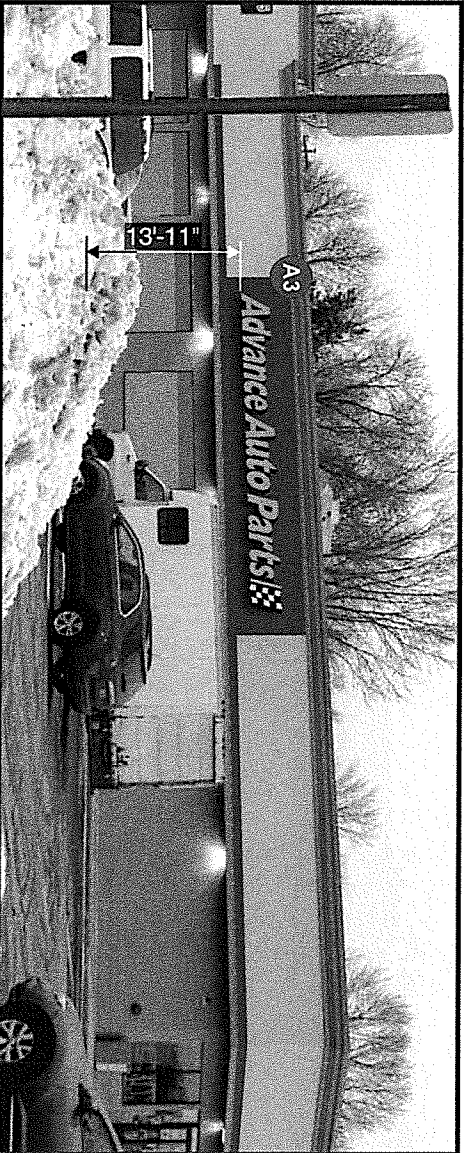

Red Background Area - Modular Red Panel System

*Signage size and placement are approximate.

B Proposed 2'-6" x 8'-0" Tenant Panel for Existing Multi-Tenant Pylon

2017 x 2' - 4017

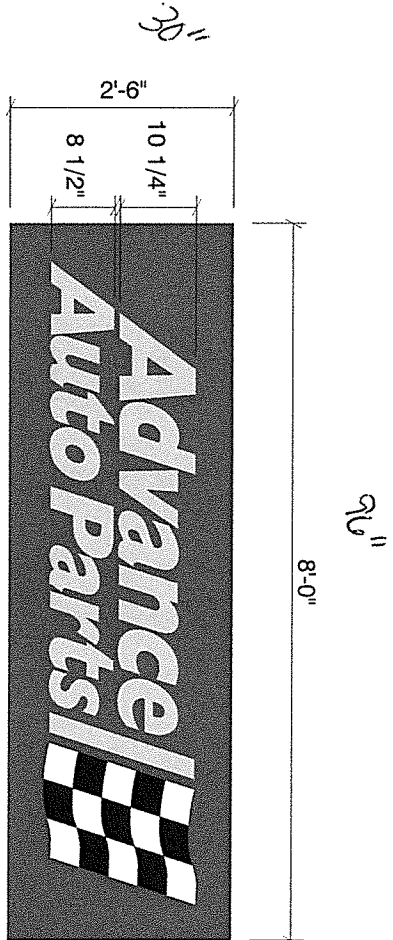

Scale: 1/2" = 1'
Sq. Ft. = 20

*Size is Approximate

- To match PMS 485C / Arlon series 2500 #33 Red
- To match PMS 108C / Arlon series 2500 #15 Yellow
- Black
- White

Existing Signage



Proposed Tenant Panel

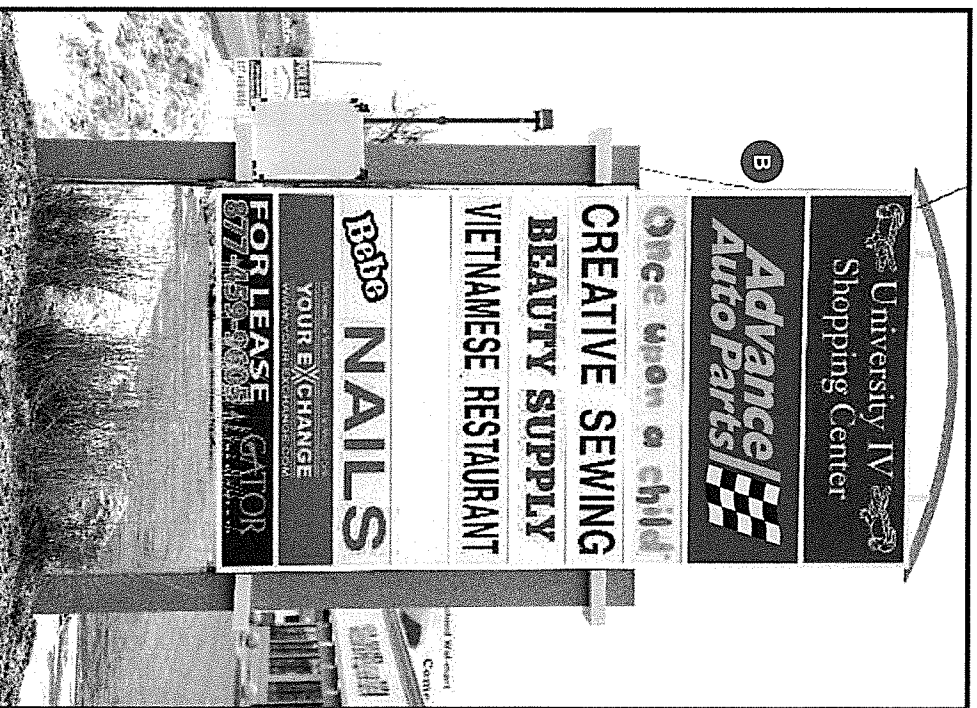

*Signage size and placement are approximate.

Tom Drapac
Director of Design and Development
Advance Stores Company, Incorporated
5008 Airport Road
Roanoke, Virginia 24012
P.O. Box 2710
Roanoke, Virginia 24001
t: 540.561.4558
f: 540.561.3430

September 22, 2014

RE: Owner Authorization

To Whom It May Concern:

This letter shall serve as written permission for Site Enhancement Services and/or their authorized agent to apply for and pursue any variances and/or permits necessary for the installation of signs on behalf of Advance Stores Company, Incorporated and its subsidiaries, Advance Auto of Puerto Rico, Inc., Advance Patriot, Inc., Autopart International, Inc., B. W. P. Distributors, Inc., Discount Auto Parts, LLC, General Parts International, Inc., Western Auto Supply Company, Western Auto of Puerto Rico, Inc., Western Auto of St. Thomas, Inc., and WORLPAC, Inc. in the United States, Canada, Mexico and Puerto Rico.

Sincerely,

Property Owner Signature/Agent

Print Name: Tom Drapac, Director of Design and Development
Property Owner Name: Advance Stores Company, Incorporated
Property Owner Address: 5008 Airport Road
Roanoke, Virginia 24012

Commonwealth of Virginia
County of Roanoke

Subscribed and sworn to before me this 22 day of September, 2014.

Notary Public Rhonda Fisher

My Commission Expires 4-30-2015

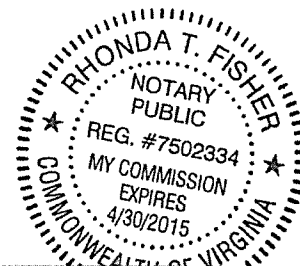

Service is our best part.™

GATOR

I N V E S T M E N T S

Via Certified Return Receipt
7014 2120 0001 5407 1184

Via Certified Return Receipt
7014 2120 0001 5007 1191

March 30, 2015

Site Enhancement Services
6001 Nimitz Parkway
South Bend, Indiana 46628

Advance Store Company, Inc. (#3512)
5008 Airport Road
Roanoke, VA 24012

RE: FASCIA SIGNAGE APPROVAL – Advance Store Company, Inc.
University IV Shopping Center – Spring Lake Park, MN

Dear Vendor and Tenant:

This letter shall serve as Landlord's written approval and authorization for Site Enhancement Services to install internally illuminated individual channel letters sign in accordance with Exhibit "D" attached to the lease, under and the following terms and conditions:

This approval is granted under the condition that Site Enhancement Services will obtain the appropriate permits and approvals required by the local governing authority prior to installation at Tenant's sole expense, the sign conforms with any and all uniform sign plan ordinances in effect; the sign is centered over the Tenant's storefront, and does not interfere with any other tenants' signage or storefront.

The tax folio number University IV Shopping Center is 45-4299073 and the ownership entity for the property is Gator University, LLLP. Attached is the legal description.

In addition, Tenant's signage must be continuously maintained in good condition at Tenant's cost and expense. Should the sign become faded or damaged in any way, Tenant shall repair or replace immediately. Should Tenant fail to do so, the Landlord shall have the right to repair Tenant's sign which shall be at Tenant's expense and shall be considered additional rent under the Lease. The cost of repairs or any damage occurring while the signage is being installed will be Tenant's responsibility.

If you should have any questions, please do not hesitate to contact the property manager, Chris Kolbe. He may be reached at 305-949-9049.

Sincerely,

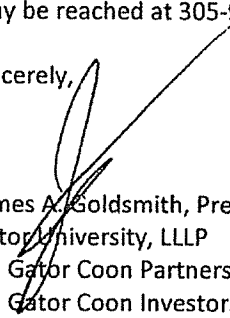
James A. Goldsmith, President
Gator University, LLLP
By: Gator Coon Partners, Ltd.
By: Gator Coon Investors, Inc.
Its: General Partner

cc: LM, MM, CK, Tenant File

Tel: 305.949.9049
Fax: 305.948.6478
1595 N.E. 163rd Street
N. Miami Beach, FL 33162
www.gatorinvestments.com

EXHIBIT "B"

Legal Description

THE LAND REFERRED TO HEREINBELOW IS SITUATED IN THE COUNTY OF ANOKA, STATE OF MINNESOTA AND IS DESCRIBED AS FOLLOWS:

Outlot 12, except the South 150 feet thereof, Terrace Manor 4th Addition, Anoka County, Minnesota.

March 10, 2015

City of Spring Lake Park
Attn: Kristine Pearson
1301 81st Avenue NE
Spring Lake Park, MN 55432

RE: Advance Auto Parts—8151 University Avenue NE

Kristine:

Enclosed is the sign permit application package for the Advance Auto Parts at 8151 University Avenue NE in Spring Lake Park, MN. I have included the sign drawings, authorization letter, and permit application. Please process the application at your earliest convenience. If everything meets with your approval, please let me know the sign permit fees. I will arrange payment and pick up of the sign permits. I appreciate your time and attention to this project.

If you have any questions or need any additional information please contact me at 855-525-6261 or jjg@siteenhancementservices.com.

Thank You,

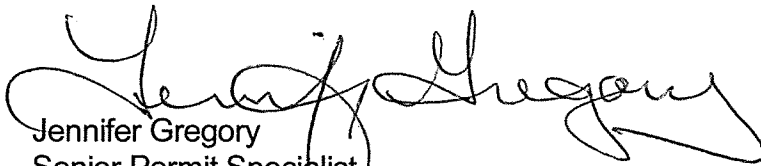

Jennifer Gregory
Senior Permit Specialist
Site Enhancement Services
6001 Nimtz Parkway
South Bend, IN 46628
P: 855-525-6261
F: 574-237-6166
jjg@siteenhancementservices.com

GATOR

I N V E S T M E N T S

Via Certified Return Receipt
7014 2120 0001 5407 1184

Via Certified Return Receipt
7014 2120 0001 5007 1191

March 30, 2015

Site Enhancement Services
6001 Nimtz Parkway
South Bend, Indiana 46628

Advance Store Company, Inc. (#3512)
5008 Airport Road
Roanoke, VA 24012

RE: FASCIA SIGNAGE APPROVAL – Advance Store Company, Inc.
University IV Shopping Center – Spring Lake Park, MN

Dear Vendor and Tenant:

This letter shall serve as Landlord's written approval and authorization for Site Enhancement Services to install internally illuminated individual channel letters sign in accordance with Exhibit "D" attached to the lease, under and the following terms and conditions:

This approval is granted under the condition that Site Enhancement Services will obtain the appropriate permits and approvals required by the local governing authority prior to installation at Tenant's sole expense, the sign conforms with any and all uniform sign plan ordinances in effect; the sign is centered over the Tenant's storefront, and does not interfere with any other tenants' signage or storefront.

The tax folio number University IV Shopping Center is 45-4299073 and the ownership entity for the property is Gator University, LLLP. Attached is the legal description.

In addition, Tenant's signage must be continuously maintained in good condition at Tenant's cost and expense. Should the sign become faded or damaged in any way, Tenant shall repair or replace immediately. Should Tenant fail to do so, the Landlord shall have the right to repair Tenant's sign which shall be at Tenant's expense and shall be considered additional rent under the Lease. The cost of repairs or any damage occurring while the signage is being installed will be Tenant's responsibility.

If you should have any questions, please do not hesitate to contact the property manager, Chris Kolbe. He may be reached at 305-949-9049.

Sincerely,

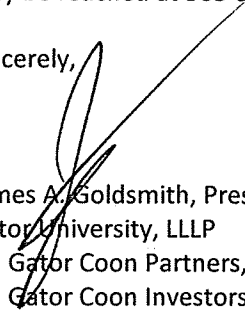

James A. Goldsmith, President
Gator University, LLLP
By: Gator Coon Partners, Ltd.
By: Gator Coon Investors, Inc.
Its: General Partner

cc: LM, MM, CK, Tenant File

Tel: 305.949.9049
Fax: 305.948.6478
1595 N.E. 163rd Street
N. Miami Beach, FL 33162
www.gatorinvestments.com

CITY OF SPRING LAKE PARK
1301 81ST AVENUE N E
SPRING LAKE PARK, MN 55432

SIGN PERMIT APPLICATION

DATE: April 7 2015
NAME OF APPLICANT: Albrecht Sign Company - Kathy Ostrom
ADDRESS OF APPLICANT: 7775 Main Street NE Fridley mn 55432
TELEPHONE NUMBER OF APPLICANT: 763-754-2899

NAME OF BUSINESS AND LOCATION of building structure, or lot to which or upon which the sign is to be attached or erected AKWAY'S Sports Barber Shop
8097 Highway 65, Ste 103 Springlake Park
New Construction: Remodel: Word Change Only:

* Attach a drawing or sketch showing the position of the sign in relation to the nearest building, structures, public streets, right-of-way and property lines. Said drawing to be prepared to scale.

Attach two (2) blueprints or ink drawings of the plans and specifications and method of construction or attachment to the building or in the ground, including all dimensions. Show location of all light sources, wattage, type and color of lights and details of light shields or shades.

Attach a copy of stress sheets and calculations showing the structure is designed for dead load and wind velocity in the amount required by this and all other Ordinances of the City, if requested by the Building Inspection Department.

Name of person, firm or corporation erecting the structure: Albrecht Sign Company

Address: 7775 Main St NE Fridley mn 55432

Is an Electrical Permit required? Yes

I, the undersigned applicant, do further make the following agreement with the City of Spring Lake Park Mn:

- 1) To authorize and direct the City of Spring Lake Park to remove and dispose of any signs and sign structures on which a Permit has been issued but which was not renewed, if the owner does not remove the same within thirty (30) days following the expiration of the Permit.
- 2) To authorize and direct the City of Spring Lake Park to remove said sign and sign structure, at the expense of the applicant, where maintenance is not furnished, but only after a hearing and after notice of sixty (60) days, specifying the maintenance required by the City.
- 3) To provide any other additional information which may be required by the Building Inspection Department.

Kathy Ostrom
SIGNATURE OF APPLICANT

FOR OFFICE USE ONLY:*****

FEE: \$160.⁰⁰

RECEIPT NUMBER: _____

DATE OF APPROVAL: _____ DATE OF ISSUE: _____

REASON FOR DENIAL: _____

ADDITIONAL REQUIREMENTS FOR SIGN PERMIT:

SQUARE FOOTAGE OF FRONT OF BUILDING: 2146

SQUARE FOOTAGE OF ALL EXISTING SIGNS: 378.5

SQUARE FOOTAGE OF PROPOSED SIGN OR SIGNS: 19

INCLUDE A DRAWING SHOWING LOCATION AND MESSAGE ON SIGN.

IF YOU ARE NOT THE OWNER OF THE PROPERTY, INCLUDE A SIGNED LETTER FROM THE OWNER GIVING PERMISSION TO ERECT THE SIGN.

NOTE: ALL APPLICATIONS ARE DUE BY NOON ON THE THURSDAY PRECEEDING THE COUNCIL MEETING.

DRAWING: Signed approval from land lord W on the drawing
see Drawings attached

Your Exchange 8.25x2 = 16.5 pylon
53 Building

Revitalife 8.75x2 = 17.5 pylon
43 Building

Snap Fitness 18x2 = 36 pylon
59 building

Caribou 8.25x2 = 16.5 pylon
45x3 = 135 Building
2 Drive thru

644 - 30%
378.5 Existing
19 proposed

246.5 Remaining

proposed

19 = \$60

197

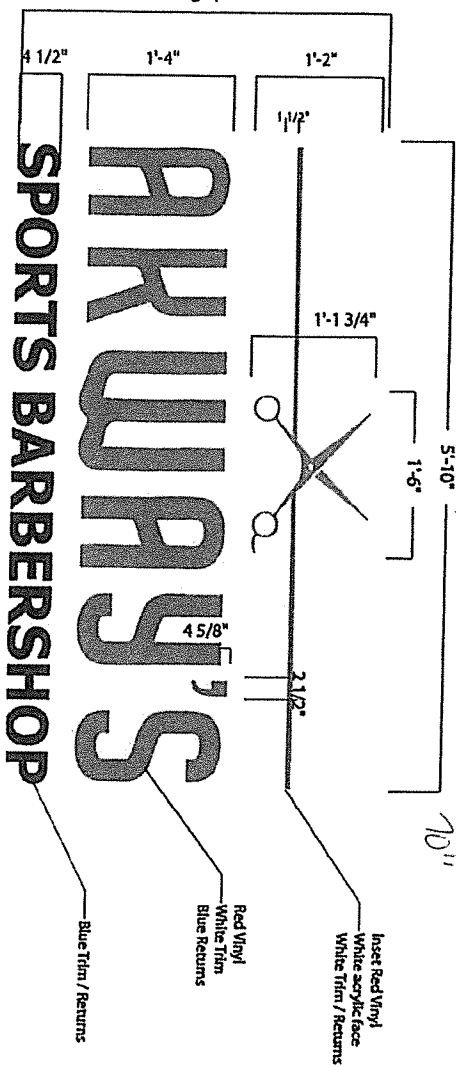
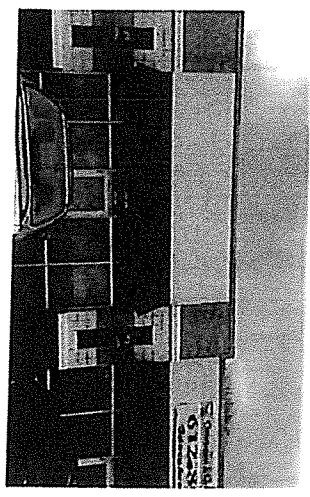
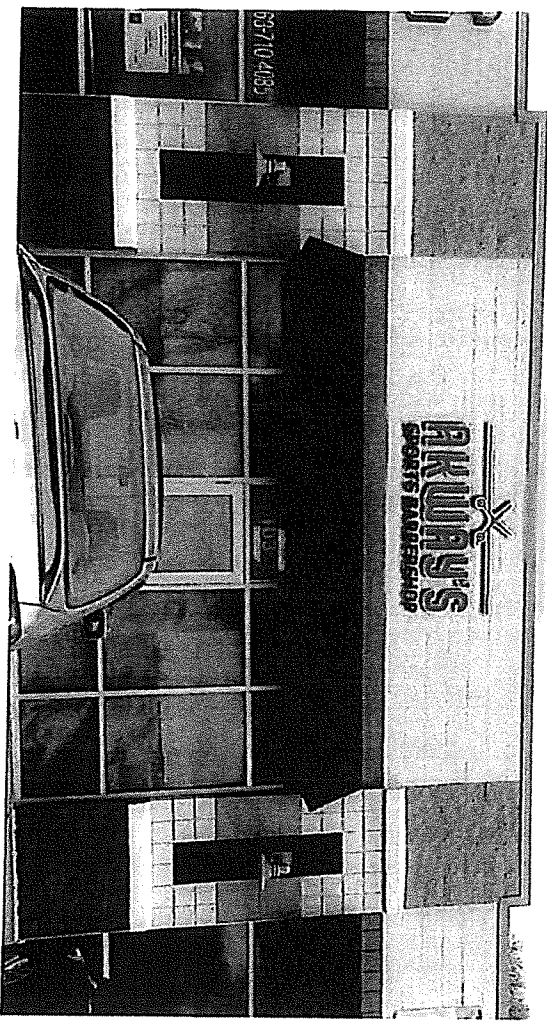

1 Illuminated Channel Letters
Scale 1" = 1' For Production/Presentation

Inset Red Vinyl
White acrylic face
White Trim / Returns
Red Vinyl
White Trim
Blue Returns
Blue Trim / Returns

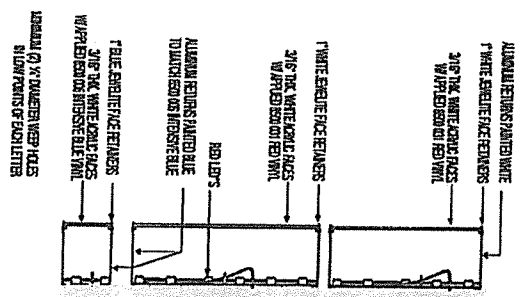

LETTER SECTION



M.T.S.

ALBERT SIGNS

- DESIGN
- FABRICATION
- INSTALLATION
- SERVICE

7775 Main St., N.E.
Fridley, MN 55422
Office: 763-754-2899
Fax: 763-67-7316

Client Name:
Alway's Sports Barbershop

Location:
597 Central Ave NE
Suite 109
Mableton, GA 30142

Start Date: 2/17/15
Last Revision: 3/28/15
Job#: 00900
Drawing Rev #: 2
Page: 1 of 1

[Signature]
Landlord Approval

Sales Rep:
Dave Albert
Designer:
MCS

LISTED
THE SIGN MANUFACTURER'S ASSOCIATION OF AMERICA
MEMBER SINCE 1988
INTERNATIONAL ASSOCIATION OF SIGNMAKERS
MEMBER SINCE 1988

Submitted 1/7/15 128 - Approved subject to local jurisdiction approvals and installation on 9/3/2015

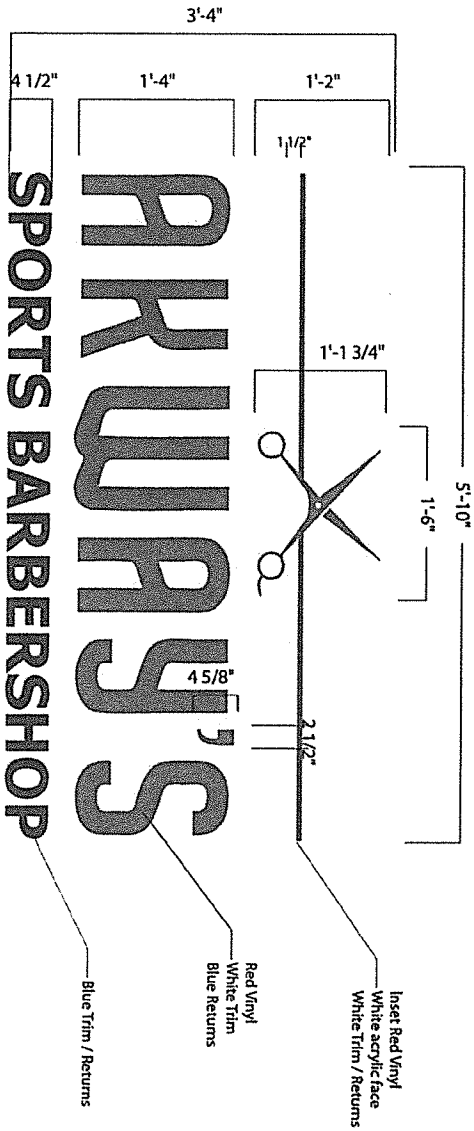
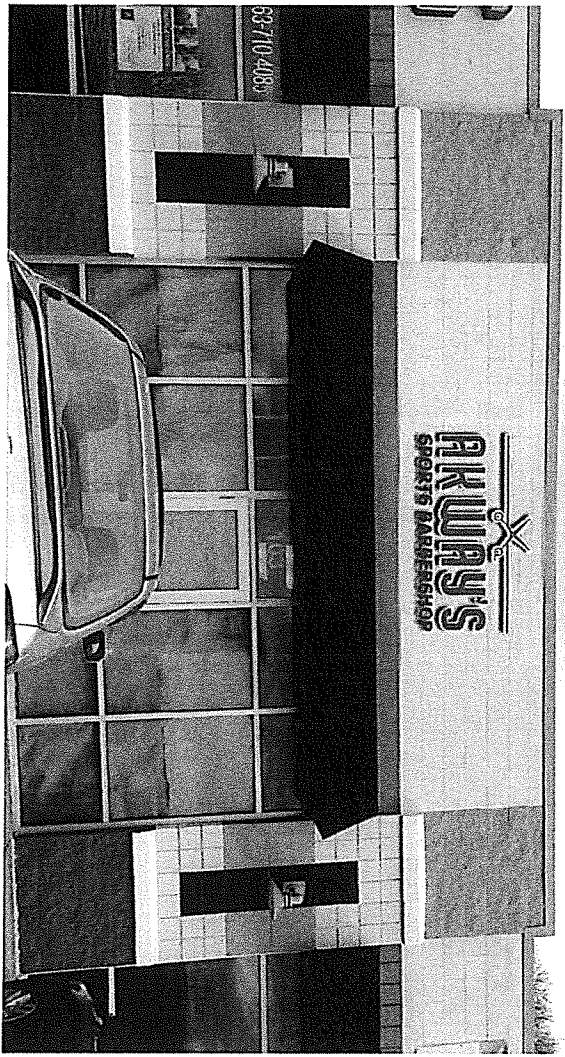

1 Illuminated Channel Letters
Scale 1" = 1' For Production / Presentation

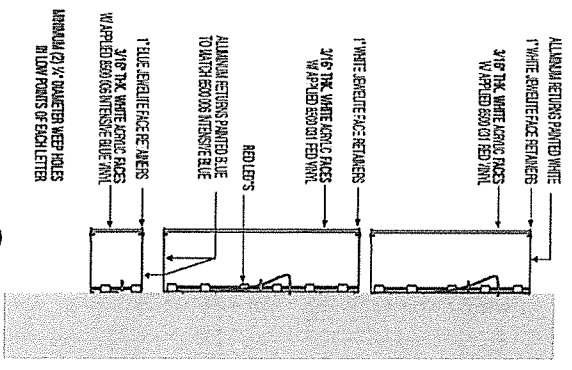

LETTER SECTION



N.T.S.



- DESIGN
- FABRICATION
- INSTALLATION
- SERVICE

7775 Main St. N.E.
Fridley, MN 55432
Office: 763-754-2899
Fax: 763-767-7316

Client Name:
Arkway's Sports BarberShop

Location:
8097 Central Ave NE
Suite 103
Minneapolis, MN 55432

Albrecht
Client Approval

Landlord Approval

Start Date: 3/17/15
Last Revision: 3/26/15
Job#: 00030
Drawing Rev #: 2
Page: 1 of 1

Sales Rep:
Dave Albrecht
Designer:
MCS



THIS SIGN AND THE LETTERS ARE MANUFACTURED IN ACCORDANCE WITH THE REQUIREMENTS OF ARTICLE 600 OF THE MINNESOTA ELECTRICAL CODE. THE INSTALLATION MUST BE IN ACCORDANCE WITH ARTICLE 600 OF THE MINNESOTA ELECTRICAL CODE.



Police Report

March 2015

Submitted for Council Meeting – April 20, 2015

The Spring Lake Park Police Department responded to three hundred and fifty-six calls for service for the month of March 2015. This compared to responding to three hundred and forty-two calls for service in March 2014.

The police department for the month of March 2015 issued thirty-nine citations, this compared to issuing two hundred and fifteen citations in March of 2014.

Each year the Spring Lake Park Police Department does an annual audit of our “Selective Intensified Traffic Enforcement Program” or more commonly known as our “S.I.T.E. Program”. This is a program that was developed in 1999 to help address traffic safety issues that were/are being experienced in our community. This program allows for residents to contact the police department and advise on problem traffic areas (Ex: Locations of continuous vehicles speeding, stop sign violations, cross walk violations, etc.) For the year 2014, the police department worked one hundred and ten S.I.T.E. shifts, stopped eight hundred and twenty-five vehicles, issued a total of nine hundred and thirty-seven citations and gave two hundred and eighty-three warnings. The total budget expended for the year 2014 was \$29,306.95. The citation revenues received for 2014 is \$29,783.60. The difference is \$476.65, which is deposited to the general fund. This program as you can see is a self-supporting program which makes it financially possible to continue to be utilized.

It is the intent of the police department with the assistance of continued driver education and programs like the S.I.T.E. Program to continue to strive to make our community the safest community possible for our residents and those visiting our community to enjoy.

The Spring Lake Park Police Department Office Staff remain steadfast in their duties, typing and imaging reports, filing, answering and dispensing phone calls for service and information, addressing citizen concerns at the “Police Public Walk up Window” along with other duties that may be assigned on a daily basis.

Investigator Baker reports carrying a case load of seventy cases for the month of March 2014, forty-three of these cases were felony in nature, sixteen of the cases were gross misdemeanor in nature and eleven of these cases were misdemeanor in nature. Investigator Baker continues to diligently work on his case load to bring the cases to a conclusion as soon as practicable. For further details, see Investigator Baker's attached report.

Officer Fiske our School Resource Officer reports handling eleven calls for service at our schools, along with conducting twenty-four student contacts, six escorts and eleven follow up investigations to school related issues. Officer Fiske noted that Spring Break was March 6th thru the 16th. Officer Fiske has noticed as the weather starts to get warmer there has been a notice difference students having disagreements and getting into fights at school and at local parks close by the school. Officer Fiske along with school staff continue to address these issues as they arise with the assistance of the police department when needed. For further details see Officer Fiske's attached report.

The month of March 2014 has been a busy month for myself as well, besides handling the day to day operations of the police department, I attended numerous meetings to include but not limited to:

- Department Head meeting held here at city hall.
- I conducting employee evaluations on each of the police department office staff
- I attended a meeting with Administrator Buchholtz and City Attorney Carson regarding Police Department issues.
- I continued to work on implementing the Traffic Education Program with our new squad computers and representative Scott Adkisson from Diversion Solutions, LLC
- I attended the Anoka County Chiefs of Police monthly meeting held in Coon Rapids, MN.
- I held a meeting with Network Access to address park camera issues we have been experiencing.
- I conducted a meeting with the police department sergeants regarding policy questions
- I attended the Board of Directors meeting at the Hibbing Community College for the Law Enforcement Program. To address potential course curriculum changes from the MN POST Board
- I attended a meeting with Chief Olson of the Blaine PD, Chief Tom Kinney of Mounds View PD and SBM Fire Chief Nyle Zikmund regarding Emergency Management Issues.

I concluded the month by participating in a committee meeting held at the League of Minnesota Cities regarding developing a boiler plate policy to be adopted by the League of Minnesota Cities that could be utilized by any city for the implementation of "Body Worn Camera Systems".

This will conclude my report for the month of March 2015.

Are there any questions?



Spring Lake Park Police Department

Investigations Monthly Report

Investigator
Brad Baker

March 2015

Total Case Load

Case Load by Level of Offense: 70

Felony	43
Gross Misdemeanor	16
Misdemeanor	11

Case Dispositions:

County Attorney	2
Juvenile County Attorney	0
City Attorney	0
Forward to Other Agency	0
SLP Liaison	0
Carried Over	64
Unfounded	0
Exceptionally Cleared	2
Closed/Inactive	2

Notes: None.

Spring Lake Park Police / School Resource Officer Report

March 1, 2015

Incidents by School Location	Reports (ICRs)	Student Contacts*	Escorts/Other	Follow Up Inv.
Spring Lake Park High School	9	22	6	10
Discovery Days (pre-school)				
Lighthouse School				
Park Terrace Elementary School	2			
District Office				
Able and Terrace Parks (School Related)				
School Related				
Miscellaneous Locations		2		1
Totals:	11	24	6	11

Breakdown of Reports (ICRs)	
Theft reports (cellphones, iPods, bikes, etc...)	1
Students charged with Assault or Disorderly Conduct	2
Students charged with other crimes	1
Non-students Charged	
Warrant Arrests	
Miscellaneous reports	7

MEMORANDUM

TO: MAYOR HANSEN AND MEMBERS OF THE CITY COUNCIL
FROM: DANIEL R. BUCHHOLTZ, CITY ADMINISTRATOR
SUBJECT: INTERIM ORDINANCE ON JOINT PARKING FACILITIES
DATE: APRIL 14, 2015

The City Council is currently working on a zoning ordinance update. The City Council has passed a development/redevelopment moratorium to provide time to the City to study and adopt new official controls.

The City Council, at its April 13 workshop, directed staff to draft a second interim ordinance relating to joint parking facilities. The ordinance governing joint parking facilities will be reviewed as part of the zoning ordinance update. The interim ordinance will prohibit new joint parking facilities from being recognized for a period of 1 year or until the zoning ordinance update process is complete to allow the City Council time to study the issue.

If you have any questions, please don't hesitate to contact me at 763-784-6491.

ORDINANCE NO. 413

**AN INTERIM ORDINANCE ESTABLISHING A MORATORIUM TEMPORARILY
PROHIBITING NEW AGREEMENTS FOR JOINT USE OF OFF-STREET PARKING
SPACES WITHIN THE CITY OF SPRING LAKE PARK**

The City Council of the City of Spring Lake Park, Minnesota, ordains as follows:

Section 1. Authority

Pursuant to the authority of Minn. Stat. §462.355, subd. 4, a municipality is permitted to adopt an interim ordinance prohibiting development within its jurisdiction, or any portion thereof, until such time as amended official controls are adopted. The interim ordinance is not to exceed one year from the date it is effective.

Section 2. Moratorium

A moratorium prohibiting new joint off-street parking facilities within the corporate limits of Spring Lake Park is hereby declared, effective upon passage and publication of this ordinance. This moratorium shall continue for a period of one (1) year or until adoption of new official controls that are currently being studied by the City in calendar year 2015.

Section 3. Effective Date

This ordinance shall be effective upon its passage and publication.

Passed by the City Council of the City of Spring Lake Park, Minnesota, this 20th day of April, 2015.

APPROVED BY:

Cindy Hansen, Mayor

ATTEST:

Daniel R. Buchholtz, Administrator, Clerk/Treasurer

MEMORANDUM

TO: MAYOR HANSEN AND MEMBERS OF THE CITY COUNCIL
FROM: DANIEL R. BUCHHOLTZ, CITY ADMINISTRATOR
SUBJECT: TOBACCO ORDINANCE UPDATE
DATE: APRIL 15, 2015

The City Council, at its April 13, 2015 workshop session, reviewed the comments the City received from its tobacco licensees on the proposed changes to the City's tobacco regulations. The City received two written comments: one from a licensee related to the proposed ban on sampling and the other from a non-profit group on the issue of child-resistant packaging for liquids used in electronic delivery devices.

The licensee, Buzz Tobacco, stated that with the cost of a carton of cigarettes ranging from \$60-\$110, customers want to sample a particular brand before making a purchase. The licensee stated that product sampling has been beneficial to his business.

The nonprofit group, Association for Nonsmokers – Minnesota, alerted us to the change in State Law mandating that tobacco licensing authorities are responsible for ensuring that any liquid intended for human consumption and use in an electronic delivery device by in child resistant packaging.

The City Council discussed the comments and made changes to the proposed ordinance to eliminate the sampling ban language and asked staff to create new definitions for smoking lounges and vapor lounges and prohibited those activities. The City Council also asked staff to create a new definition for child-resistant packaging and added language to the ordinance to make it unlawful for any licensee to sell any liquid, whether or not such liquid contains nicotine, that is intended for human consumption and use in an electronic delivery device, that is not in child resistant packaging.

The City Council also discussed the combination of the violations and penalties sections of the ordinance into one section for ease of administration. The Council was supportive of that change.

Staff expresses its thanks to the City Council and the City's tobacco licensees for the time spent reviewing this ordinance. Staff recommends approval of the ordinance as presented.

If you have any questions, please don't hesitate to contact me at 763-784-6491.

ORDINANCE NO. 414

AN ORDINANCE AMENDING CHAPTER 112 OF THE SPRING LAKE PARK CODE OF ORDINANCE RELATING TO TOBACCO REGULATIONS

The City Council of the City of Spring Lake Park, Minnesota, ordains as follows:

Section 1. §112.01 shall hereby be amended as follows:

Because the city recognizes that many persons under the age of 18 years purchase or otherwise obtain, possess, and use tobacco-related products, ~~tobacco products, and tobacco-related devices~~, and those sales, possession, and use are violations of both state and federal laws; and because studies, which are hereby accepted and adopted, have shown that most smokers begin smoking before they have reached the age of 18 years and that those persons who reach the age of 18 years without having started smoking are significantly less likely to begin smoking; and because smoking has been shown to be the cause of several serious health problems which subsequently place a financial burden on all levels of government; this chapter shall be intended to regulate the sale, possession, and use of tobacco-related products, ~~tobacco products, and tobacco-related devices~~ for the purpose of enforcing and furthering existing laws, to protect minors against the serious effects associated with the illegal use of tobacco-related products, ~~tobacco products, and tobacco-related devices~~, and to further the official public policy of the state in regard to preventing young people from starting to smoke as stated in M.S. § 144.391, as it may be amended from time to time.

Section 2. §112.02 shall hereby be amended to add/amend the following definitions:

CHILD RESISTANT PACKAGING. Packaging that meets the definition set forth in Code of Federal Regulations, title 16, section 1700.15(b)(1), as in effect on January 1, 2015, when tested in accordance with the methods described in Code of Federal Regulations, title 16, section 1700.20, as in effect on January 1, 2015

ELECTRONIC DELIVERY DEVICES. Any product containing or delivering nicotine, lobelia, or any other substance intended for human consumption that can be used by a person to simulate smoking in the delivery of nicotine or any other substance through inhalation of vapor from the product. Electronic delivery device includes any component part of a product, whether or not marketed or sold separately. Electronic delivery device does not include any product that has been approved or certified by the United States Food and Drug Administration for sale as a tobacco-cessation product, as a tobacco-dependence product, or for other medical purposes, and is marketed and sold for such an approved purpose.

LOOSIES. The common term used to refer to a single or individually packaged cigarette or any other tobacco product that has been removed from its packaging and sold individually. The term **LOOSIES** does not include individual cigars with a retail price, before any sales taxes, of more than \$2.00 per cigar.

NICOTINE OR LOBELIA DELIVERY DEVICES. Any product containing or delivering nicotine or lobelia intended for human consumption, or any part of such a product, that is not tobacco as defined in this section, not including any product that has been approved or otherwise certified for legal sale by the United States Food and Drug Administration for tobacco

use cessation, harm reduction, or for other medical purposes, and is being marketed and sold solely for that approved purpose.

RETAIL ESTABLISHMENT. Any place of business where ~~tobacco-related products;~~ ~~tobacco products,~~ or ~~tobacco related devices~~ are available for sale to the general public. ***RETAIL ESTABLISHMENTS*** include, but are not limited to, grocery stores, convenience stores, and restaurants.

SELF-SERVICE MERCHANDISING. Open displays of ~~tobacco-related products;~~ ~~tobacco products,~~ or ~~tobacco related devices~~ in any manner where any person shall have access to the ~~tobacco-related products,~~ ~~tobacco products,~~ or ~~tobacco related devices,~~ without the assistance or intervention of the licensee or the licensee's employee. The assistance or intervention shall entail the actual physical exchange of the ~~tobacco-related products,~~ ~~tobacco product,~~ or ~~tobacco-related device~~ between the customer and the licensee or employee. ***SELF-SERVICE MERCHANDISING*** shall not include vending machines.

SMOKING LOUNGE. A location licensed to sell tobacco products where: (a) except for a bona fide sale of a smoking device, provided or otherwise made available for use by a customer, potential customer or any other person a smoking device for the purpose of smoking any tobacco product; (b) it is provided in exchange for a fee or any other consideration seating within or access to the indoor area of a tobacco products shop; or (c) it is permitted within the indoor area the sampling of any tobacco product which was not furnished by the tobacco products shop on the date and at the time the sampling occurs.

TOBACCO or TOBACCO PRODUCTS. Any substance or item containing tobacco leaf, including but not limited to cigarettes; cigars; pipe tobacco; snuff, fine cut or other chewing tobacco; cheroots; stogies; perique; granulated, plug cut, crimp cut, ready rubbed, and other smoking tobacco; snuff flowers; cavendish; shorts; plug and twist tobaccos; dipping tobaccos; refuse scraps, clippings, cuttings, sweepings of tobacco; and other kinds and forms of tobacco leaf prepared in manner so as to be suitable for chewing, sniffing, or smoking. Tobacco includes cigarettes and any product containing, made, or derived from tobacco that is intended for human consumption, whether chewed, smoked, absorbed, dissolved, inhaled, snorted, sniffed, or ingested by any other means, or any component, part, or accessory of a tobacco product; cigars; cheroots; stogies; perique; granulated, plug cut, crimp cut, ready rubbed, and other smoking tobacco; snuff; snuff flour; cavendish; plug and twist tobacco; fine cut and other chewing tobaccos; shorts; refuse scraps, clippings, cuttings and sweepings of tobacco; and other kinds and forms of tobacco. Tobacco excludes any tobacco product that has been approved by the United States Food and Drug Administration for sale as a tobacco cessation product, as a tobacco dependence product, or for other medical purposes, and is being marketed and sold solely for such an approved purpose.

TOBACCO-RELATED DEVICES. Any tobacco product, as well as a pipe, rolling papers or other device intentionally designed or intended to be used in a manner which enables the chewing, sniffing, ~~or~~ smoking, or inhalation of vapors of tobacco or tobacco products.

TOBACCO-RELATED PRODUCTS. Includes tobacco or tobacco products, tobacco-related devices, electronic delivery devices and nicotine and lobelia delivery devices.

VAPOR LOUNGE. A location that sells electronic delivery devices where: (a) except for a bona fide sale of a smoking device, provided or otherwise made available for use by a customer, potential customer, or any other person a device or product for the purpose of using an electronic delivery device product; (b) it is provided in exchange for a fee or any other consideration seating

within or access to the indoor area of a shop that sells electronic delivery devices; or (c) it is permitted within the indoor area of a shop that sells electronic delivery devices the sampling of any electronic delivery device which was not furnished by the shop on the date and time the sampling occurs.

VENDING MACHINE. Any mechanical, electric, or electronic, or other type of device which dispenses tobacco-related products, ~~tobacco products, or tobacco-related devices~~ upon the insertion of money, tokens, or other form of payment directly into the machine by the person seeking to purchase the tobacco-related product, ~~tobacco product, or tobacco-related device.~~

Section 3. §112.03 shall hereby be amended to read as follows:

§ 112.03 LICENSE.

(A) *License required.* No person shall sell or offer to sell any tobacco-related products, ~~tobacco products, or tobacco-related device~~ without first having obtained a license to do so from the city.

(B) *Application.* An application for a license to sell tobacco-related products, ~~tobacco products, or tobacco-related devices~~ shall be made on a form provided by the city. The application shall contain the full name of the applicant, the applicant's residential and business addresses and telephone numbers, the name of the business for which the license is sought, and any additional information the city deems necessary. Upon receipt of a completed application, the City Administrator, Clerk/Treasurer shall forward the application to the Police Department for the purpose of conducting a background check on the applicant. The Police Department shall have ten days to complete the background check, and upon its completion shall forward the application and investigation results to the City Council for action at its next regularly scheduled Council meeting. If the Administrator, Clerk/Treasurer shall determine that an application is incomplete, he or she shall return the application to the applicant with notice of the information necessary to make the application complete.

(C) *Action.* The City Council may either approve or deny the license, or it may delay action for a reasonable period of time as necessary to complete any investigation of the application or the applicant it deems necessary. If the City Council shall approve the license, the Administrator, Clerk/Treasurer shall issue the license to the applicant. If the City Council denies the license, notice of the denial shall be given to the applicant along with notice of the applicant's right to appeal the decision.

(D) *Term.* All licenses issued under this chapter shall expire on December 31 of each year.

(E) *Revocation or suspension.* Any license issued under this chapter may be revoked or suspended as provided in §§ 112.12 and 112.99 of this code.

(F) *Transfers.* All licenses issued under this chapter shall be valid only on the premises for which the license was issued and only for the person to whom the license was issued. No transfer of any license to another location or person shall be valid without the prior approval of the City Council.

(G) *Moveable place of business.* No license shall be issued to a moveable place of business. Only fixed location businesses shall be eligible to be licensed under this chapter.

(H) *Display.* All licenses shall be posted and displayed in plain view of the general public on the licensed premises.

(I) *Renewals.* The renewal of a license issued under this section shall be handled in the same manner as the original application. The request for a renewal shall be made at least 30 days but not more than 60 days before the expiration of the current license.

(J) *Issuance as privilege and not a right.* The issuance of a license issued under this section shall be considered a privilege and not an absolute right of the applicant and shall not entitle the holder to an automatic renewal of the license.

Section 4. §112.04 shall hereby be amended to read as follows:

§ 112.04 LICENSE FEES.

No license shall be issued under this chapter until the appropriate license fee shall be paid in full. The annual fee for a license under this chapter shall be ~~set from time to time by Council resolution~~ established in the city's Ordinance Establishing Fees and Charges, as may be amended from time to time. Initial license applications covering a period of less than one year shall be charged a fee calculated on a monthly pro rata basis.

Section 5. §112.05 shall hereby be amended to read as follows:

§ 112.05 BASIS FOR DENIAL OF LICENSE.

(A) The following shall be grounds for denying the issuance or renewal of a license under this chapter; however, except as may otherwise be provided by law, the existence of any particular ground for denial does not mean that the city must deny the license:

(1) The applicant is under the age of 18 years;

(2) The applicant has been convicted within the past five years of any violation of a federal, state, or local law, ordinance provision, or other regulation relating to tobacco-related products, tobacco products, or tobacco-related devices;

(3) The applicant has had a license to sell tobacco-related products, tobacco products, or tobacco-related devices revoked within the preceding 12 months of the date of the application;

(4) The applicant fails to provide any information required on the application, or provides false or misleading information; or

(5) The applicant is prohibited by federal, state, or other local law, ordinance, or other regulation, from holding this type of license.

(B) If a license is mistakenly issued or renewed to a person, it shall be revoked upon the discovery that the person was ineligible for the license under this section.

Section 6. §112.06 shall hereby be amended to read as follows:

§ 112.06 UNLAWFUL SALES.

It shall be a violation of this chapter for any person to sell any tobacco, tobacco product, or tobacco-related device:

- (A) To any person under the age of 18 years;
- (B) By means of any type of vending machine, except as may otherwise be provided in this chapter;
- (C) By means of self-service methods whereby the customer does not need to make a verbal or written request to an employee of the licensed premises in order to receive the tobacco-related product, ~~tobacco product, or tobacco-related device~~ and whereby there is not a physical exchange of the tobacco-related product, ~~tobacco product, or tobacco-related device~~ between the licensee or the licensee's employee, and the customer, except as may otherwise be provided in this chapter;
- (D) By means of loosies as defined in § 112.02 of this code;
- (E) Containing opium, morphine, jimson weed, bella donna, strychnos, cocaine, marijuana, or other deleterious, hallucinogenic, toxic, or other controlled substances except nicotine and other substances found naturally in tobacco or added as part of an otherwise lawful manufacturing process; or
- (F) By any other means, to any other person, or in any other manner or form prohibited by federal, state, or other local law, ordinance provision, or other regulation.

Section 7. §112.07 shall hereby be amended to read as follows:

§ 112.07 VENDING MACHINES-RESTRICTED.

It shall be unlawful for any person licensed under this chapter to allow the sale of tobacco-related products, ~~tobacco products, or tobacco-related devices~~ by the means of a self-service vending machine unless minors are at all times prohibited from entering the licensed establishment.

Section 8. §112.08 shall hereby be amended to read as follows:

§ 112.08 SELF-SERVICE MERCHANDISING PROHIBITED.

It shall be unlawful for a licensee under this chapter to allow the sale of tobacco-related products, ~~tobacco products, or tobacco-related devices~~ by any means whereby the customer may have access to those items without having to request the item from the licensee or the licensee's employee and whereby there is not a physical exchange of the tobacco-related products, ~~tobacco product, or tobacco-related device~~ between the licensee or his or her clerk and the customer. All tobacco-related products, ~~tobacco products, and tobacco-related devices~~ shall either be stored behind a counter or other area, not freely accessible to customers, or in a case or other storage unit not left open and accessible to the general public. Any retailer selling tobacco-related products, ~~tobacco products, or tobacco-related devices~~ at the time this chapter is adopted shall

comply with this section within 90 days. This section shall not apply to retail stores which derive at least 90% of their revenue from tobacco-related products, ~~tobacco products~~, or ~~tobacco-related devices~~ and which cannot be entered at any time by persons younger than 18 years of age.

Section 9. §112.09 shall hereby be amended to read as follows:

§ 112.09 LICENSEE RESPONSIBILITY.

All licensees under this chapter shall be responsible for the actions of their employees in regard to the sale of tobacco-related products, ~~tobacco products~~, or ~~tobacco-related devices~~ on the licensed premises, and the sale of such an item by an employee shall be considered a sale by the license holder. Nothing in this section shall be construed as prohibiting the city from also subjecting the clerk to whatever penalties are appropriate under this code, state or federal law, or other applicable law or regulation.

Section 10. §112.10 shall hereby be amended to read as follows:

§ 112.10 COMPLIANCE CHECKS.

All licensed premises shall be open to inspection by the City Police Department during regular business hours. From time to time, but at least once per year, the city shall conduct compliance checks by engaging, with the written consent of their parent or guardian, minors over the age of 15 years but less than 18 years, to enter the licensed premises to attempt to purchase tobacco-related products, ~~tobacco products~~, or ~~tobacco-related devices~~. Minors used for the purpose of compliance checks shall be supervised by designated law enforcement officers or other designated city personnel. Minors used for compliance checks shall not be guilty of an unlawful purchase or attempted purchase, nor the unlawful possession of tobacco-related products, ~~tobacco products~~, or ~~tobacco-related devices~~ when those items are obtained or attempted to be obtained as a part of the compliance check. No minor used in compliance checks shall attempt to use a false identification misrepresenting the minor's age, and all minors lawfully engaged in a compliance check shall answer all questions about the minor's age asked by the licensee or his or her employee and shall produce any identification, if any exists, for which he or she is asked. Nothing in this section shall prohibit compliance checks authorized by state or federal laws for educational, research, or training purposes, or required for the enforcement of a particular state or federal law.

Section 11. §112.11 shall hereby be amended to read as follows:

§ 112.11 OTHER ILLEGAL ACTS.

(A) *Illegal sales.* It shall be a violation of this chapter for any person to sell or otherwise provide any tobacco-related product, ~~tobacco product~~, or ~~tobacco-related device~~ to any minor.

(B) *Illegal possession.* It shall be a violation of this chapter for any minor to have in his or her possession any tobacco-related product, ~~tobacco product~~, or ~~tobacco-related device~~. This division shall not apply to minors lawfully involved in a compliance check.

(C) *Illegal use.* It shall be a violation of this chapter for any minor to smoke, chew, sniff, or otherwise use any tobacco-related product, ~~tobacco product~~, or ~~tobacco-related device~~.

(D) *Illegal procurement.* It shall be a violation of this chapter for any minor to purchase or attempt to purchase or otherwise obtain any ~~tobacco-related product, tobacco product, or tobacco-related device~~, and it shall be a violation of this chapter for any person to purchase or otherwise obtain items of this type on behalf of a minor. It shall further be a violation for any person to coerce or attempt to coerce a minor to illegally purchase or otherwise obtain or use any ~~tobacco-related product, tobacco product, or tobacco-related device~~. This division shall not apply to minors lawfully involved in a compliance check.

(E) *False identification.* It shall be a violation of this chapter for any minor to attempt to disguise his or her true age by the use of a false form of identification, whether the identification is that of another person or one on which the age of the person has been modified or tampered with to represent an age older than the actual age of the person.

(F) *Liquid packaging.* Effective January 1, 2015, it shall be a violation of this section for any licensee to sell any liquid, whether or not such liquid contains nicotine, that is intended for human consumption and use in an electronic delivery device, that is not in child resistant packaging.

Section 12. Chapter 112 of the Spring Lake Park City Code is amended to read as follows:

§ 112.12 VIOLATIONS; ENFORCEMENT. SMOKING AND VAPOR LOUNGES

Smoking lounges and vapor lounges are prohibited.

~~———— (A) ——— Notice. Upon discovery of a suspected violation, the alleged violator shall be issued, either personally or by mail, an administrative offense citation pursuant to Ch. 34 of this code, setting forth the alleged violation and the alleged violator’s right to be heard on the accusation.~~

~~———— (B) ——— Hearing. The person accused of violating this chapter may request a hearing in writing within 14 days of receipt of the notice of violation, and a hearing shall be scheduled, the time and place of which shall be provided to the accused violator.~~

~~———— (C) ——— Hearing officer. The Administrator, Clerk/Treasurer or his or her designee shall serve as the hearing officer.~~

~~———— (D) ——— Decision. If the hearing officer determines that a violation of this chapter did occur, that decision, along with the hearing officer’s reasons for finding a violation and the penalty to be imposed under § 112.99 of this code, shall be recorded in writing, a copy of which shall be provided to the accused violator. Likewise, if the hearing officer finds that no violation occurred or finds grounds for not imposing any penalty, those findings shall be recorded and a copy provided to the acquitted accused violator.~~

~~———— (E) ——— Appeal. Appeals of any decision made by the hearing officer shall be made to the City Council in writing within seven days of receipt of the hearing officer’s decision. The decision of the City Council shall be final.~~

~~———— (F) ——— Misdemeanor prosecution. A violation of this chapter shall be a misdemeanor.~~

~~———— (G) ——— Continued violation. Each violation, and every day in which a violation occurs or continues, shall constitute a separate offense.~~

Section 13. §112.99 shall hereby be amended to read as follows:

§ 112.99. VIOLATIONS AND PENALTY

(A) Misdemeanor prosecution. Noting in this chapter shall prohibit the city from seeking prosecution as a misdemeanor for any alleged violation of this ordinance.

(B) Violations.

(1) Notice. Upon discovery of a suspected violation, the alleged violator shall be issued, either personally or by mail, an administrative offense citation pursuant to Ch. 34 of this code, setting forth the alleged violation and the alleged violator's right to be heard on the accusation.

(2) Hearing. The person accused of violating this chapter may request a hearing in writing within 14 days of receipt of the notice of violation, and a hearing shall be scheduled, the time and place of which shall be provided to the accused violator.

(3) Hearing officer. The Administrator, Clerk/Treasurer or his or her designee shall serve as the hearing officer.

(4) Decision. If the hearing officer determines that a violation of this chapter did occur, that decision, along with the hearing officer's reasons for finding a violation and the penalty to be imposed under § 112.99 of this code, shall be recorded in writing, a copy of which shall be provided to the accused violator. Likewise, if the hearing officer finds that no violation occurred or finds grounds for not imposing any penalty, those findings shall be recorded and a copy provided to the acquitted accused violator.

(5) Appeal. Appeals of any decision made by the hearing officer shall be made to the City Council in writing within seven days of receipt of the hearing officer's decision. The decision of the City Council shall be final.

(6) Continued violation. Each violation, and every day in which a violation occurs or continues, shall constitute a separate offense.

(C) Administrative penalties.

(A1) Licensees. Any licensee found to have violated this chapter, or whose employee shall have violated this chapter, shall be charged an administrative fine of \$75 for a first violation of this chapter, \$200 for a second offense at the same licensed premises within a 24-month period, and \$250 for a third or subsequent offense at the same location within a 24-month period. After the third offense, the license is automatically suspended for seven days commencing the day following the date of the third offense. In addition to the seven-day suspension, the City Council shall conduct a hearing at the regular Council meeting following the third violation to determine whether the license should be suspended longer than seven days. Any additional suspension may be for the remainder of the license period or 90 days, whichever is greater.

(B2) Other individuals. Other individuals, other than minors regulated by division (C)(3) of this section, found to be in violation of this chapter shall be charged an administrative fine of \$50.

(E3) *Minors.* Minors found in unlawful possession of, or who unlawfully purchase, or attempt to purchase, tobacco-related products, tobacco products, or tobacco-related devices may be referred to the Anoka County Attorney's Office.

(D4) *Misdemeanor.* ~~Any person found guilty by a lawful authority of violating any provisions of this chapter shall be guilty of a misdemeanor.~~ Statutory penalties. If the administrative penalties authorized to be imposed by M.S. §461.12, as it may be amended from time to time, differ from these established in this section, then the statutory penalties shall prevail.

Section 14. This Ordinance shall have full force and effect upon its passage and publication.

Section 15. The Council hereby determines that the text of the summary of this ordinance marked "Official Summary of Ordinance No. 414" and a copy of which is attached to this ordinance, clearly informs the public of the intent and effect of this ordinance. The Council further determines that publication of the title and this summary will clearly inform the public of the intent and effect of this ordinance. The Administrator, Clerk/Treasurer shall file a copy of this ordinance and the summary in the Administrator, Clerk/Treasurer's office which shall be available for inspection by any person during regular office hours.

Passed by the City Council of the City of Spring Lake Park, Minnesota, this 20th day of April 2015.

Cindy Hansen, Mayor

ATTEST:

Daniel R. Buchholtz, City Administrator/Clerk

OFFICIAL SUMMARY OF ORDINANCE NO. 414
AN ORDINANCE AMENDING CHAPTER 112 OF THE SPRING LAKE PARK CODE OF
ORDINANCE RELATING TO TOBACCO REGULATIONS

The following is the official summary of Ordinance No. 414, which was passed by the City Council on April 20, 2015.

A printed copy of this ordinance is available for inspection by any person at the office of the Administrator, Clerk/Treasurer during normal business hours or on the City's website at www.slpmn.org.

The ordinance amends Chapter 112 of the Spring Lake Park Code of Ordinance Relating to Tobacco Regulations as follows:

Amends §112.02 to add definitions for "child resistant packaging," "electronic delivery devices," "nicotine or lobelia delivery devices," "smoking lounge," "tobacco-related products," "vapor lounge" and amends definitions for "loosies," "retail establishment," "tobacco or tobacco products," "tobacco-related devices," and "vending machine."

Replaces the words "tobacco, tobacco products, or tobacco related device" throughout the ordinance with "tobacco-related products."

Adds (J) to §113.03 to state that issuance of a tobacco license is a privilege and not a right.

Adds (F) to §112.11 to state that, effective January 1, 2015, it is a violation of the ordinance for any licensee to sell any liquid, whether or not such liquid contains nicotine, that is intended for human consumption and use in an electronic delivery device, that is not in child resistant packaging.

Repeals §112.12 and replaces with language stating that smoking lounges and vapor lounges are prohibited.

Amends §112.99 relating to penalties for violation of the ordinance to include administrative penalties.

The effective date of the ordinance is the date of the publication of this summary of the ordinance. The ordinance adopts this summary of the ordinance.

This summary was approved by the City Council of Spring Lake Park, Minnesota, on April 20, 2015.

APPROVED BY:

Cindy Hansen, Mayor

ATTEST:

Daniel R. Buchholtz, Administrator/Clerk

MEMORANDUM

TO: MAYOR HANSEN AND MEMBERS OF THE CITY COUNCIL
FROM: DANIEL R. BUCHHOLTZ, CITY ADMINISTRATOR
SUBJECT: LOT LINE ADJUSTMENT – 8201 CENTRAL AVENUE NE
DATE: APRIL 15, 2015

Ron & Carol Peil, owners of Units H, I and J, Spring Lake Park Number Two Condominiums, located at 8201 Central Avenue NE, have requested a unit lot line adjustment between Units I and J. During their ownership and use, the wall between units I and J was moved to give more space to Unit J. The remainder of Unit I was leased with Unit H.

The owners have a purchase agreement to sell Units H and I to a company that provides chimney and masonry services, as well as selling and installing gas and wood fireplace inserts. The purchase agreement is subject to the approval of the lot line adjustment. The Spring Lake Park Number Two Condominium Association has approved the request. Staff is asking the same from the Council through approval of Resolution 15-9, which is included in the Council packet.

If you have any questions, please don't hesitate to contact me at 763-784-6491.

RESOLUTION NO. 15-09

A RESOLUTION APPROVING LOT LINE ADJUSTMENT BETWEEN UNIT I AND UNIT J, COMMON INTEREST COMMUNITY NUMBER 207, SPRING LAKE PARK NUMBER TWO CONDOMINIUMS

WHEREAS, the City of Spring Lake Park received a request from Ron and Carol Peil, RonCar, LLC, owners of Units H, I and J, Common Interest Community Number 207, Spring Lake Park Number Two Condominiums being located upon Lot 9, Block 1, Gonyea's Addition, Anoka County (8201 Central Avenue NE) to adjust the property lines common to Units I and J, as described in Exhibit A; and

WHEREAS, the requested adjustment is made solely for the purpose of relocating property lines; and

WHEREAS, the requested adjustment complies with the provisions of the City's Zoning Code; and

WHEREAS, the proposed lot split was reviewed and approved by the association for Common Interest Community Number 207, Spring Lake Park Number Two Condominiums

NOW, THEREFORE, BE IT RESOLVED by the City Council of the City of Spring Lake Park, Minnesota that the City Council does hereby grant approval of said property line adjustment and allow said property line adjustment to be legally recorded.

The foregoing Resolution was moved for adoption by .

Upon Vote being taken thereon, the following voted in favor thereof:

And the following voted against the same:

Whereon the Mayor declared said Resolution duly passed and adopted the 3rd day of November, 2014.

APPROVED BY:

Cindy Hansen, Mayor

ATTEST:

Daniel R. Buchholtz, City Administrator

EXHIBIT A

**COMMON INTEREST COMMUNITY NUMBER TWO
SPRING LAKE PARK NUMBER TWO CONDOMINIUMS
A CONDOMINIUM
FIRST AMENDED COMMON INTEREST COMMUNITY PLAT**

Existing Legal Description:

Unit I, CIC No. 207, A Condominium, Spring Lake Park Number Two Condominiums being located upon:
Lot 9, Block 1, Gonyea's Addition, Anoka County, Minnesota

Unit J, CIC No. 207, A Condominium, Spring Lake Park Number Two Condominiums being located upon:
Lot 9, Block 1, Gonyea's Addition, Anoka County, Minnesota

Proposed Legal Description

Unit I1, CIC No. 207, A Condominium, Spring Lake Park Number Two Condominiums being located upon:
Lot 9, Block 1, Gonyea's Addition, Anoka County, Minnesota

Unit J1, CIC No. 207, A Condominium, Spring Lake Park Number Two Condominiums being located upon:
Lot 9, Block 1, Gonyea's Addition, Anoka County, Minnesota

SEE FIRST AMENDED COMMON INTEREST COMMUNITY PLAT

**COMMON INTEREST COMMUNITY NUMBER 207
 SPRING LAKE PARK NUMBER TWO CONDOMINIUMS
 A CONDOMINIUM
 FIRST AMENDED COMMON INTEREST COMMUNITY PLAT**

THIS FIRST AMENDED COMMON INTEREST COMMUNITY PLAT IS PART OF THE DECLARATION RECORDED AS DOCUMENT NO. _____ ON THIS _____ DAY OF _____, 20____.

**CITY OF SPRING LAKE PARK
 COUNTY OF ANOKA
 SEC. 1, T. 30, R. 24**

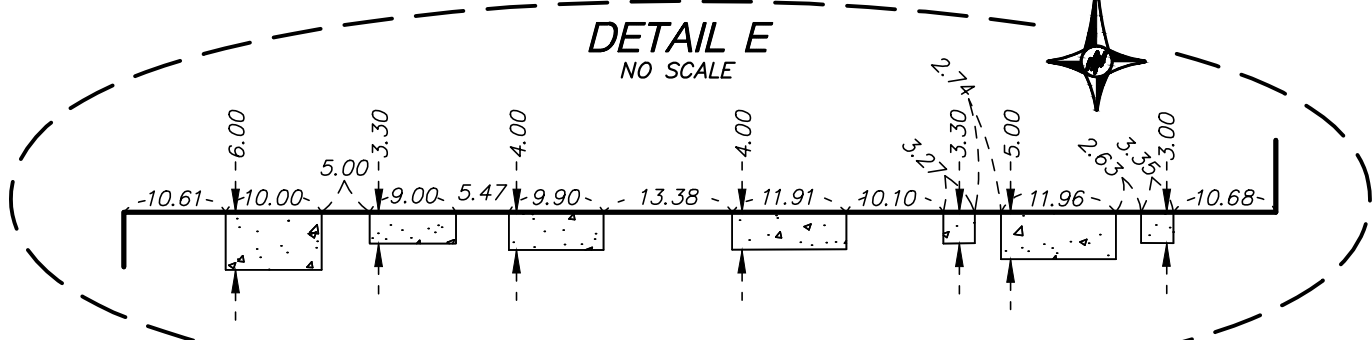
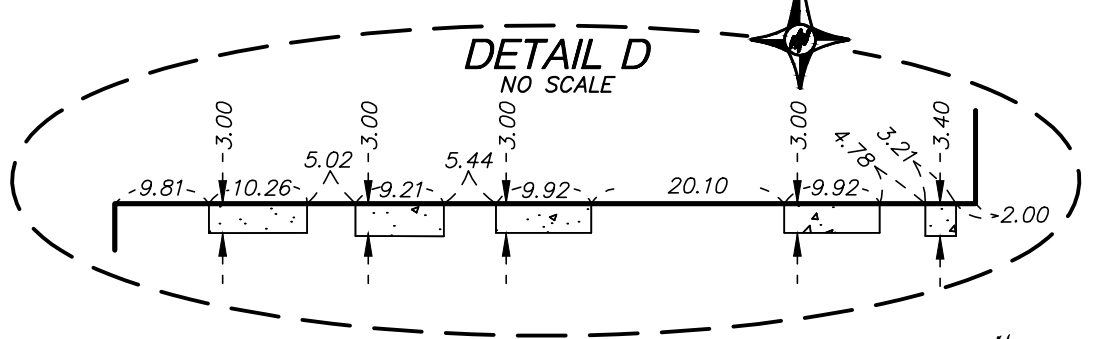
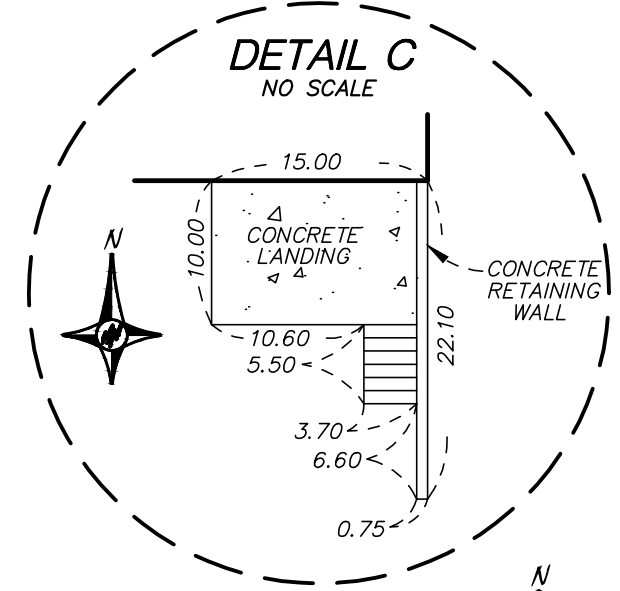
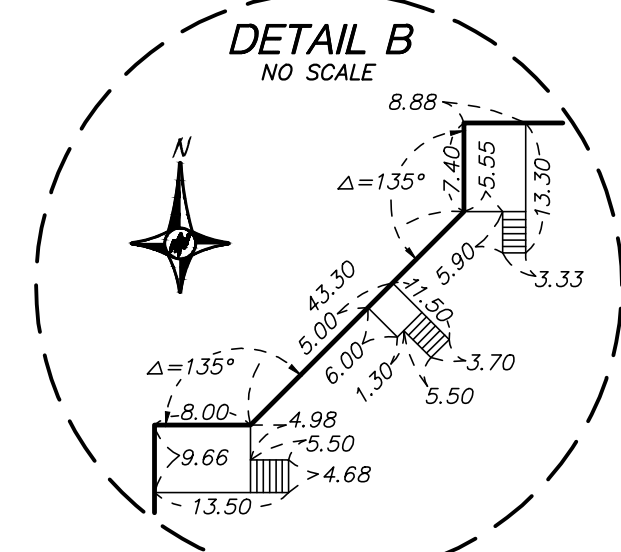
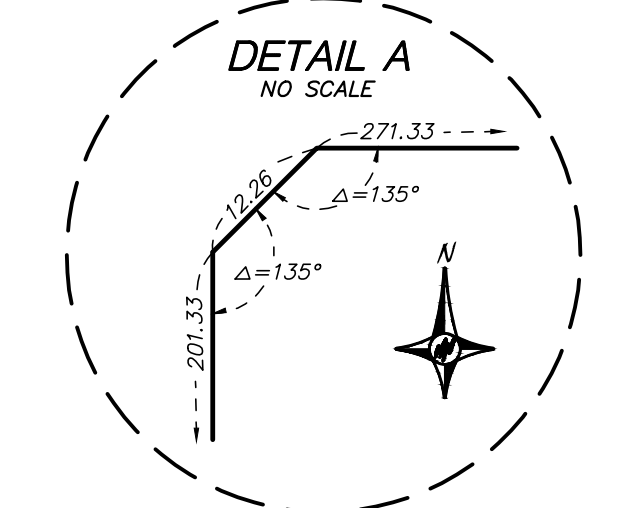
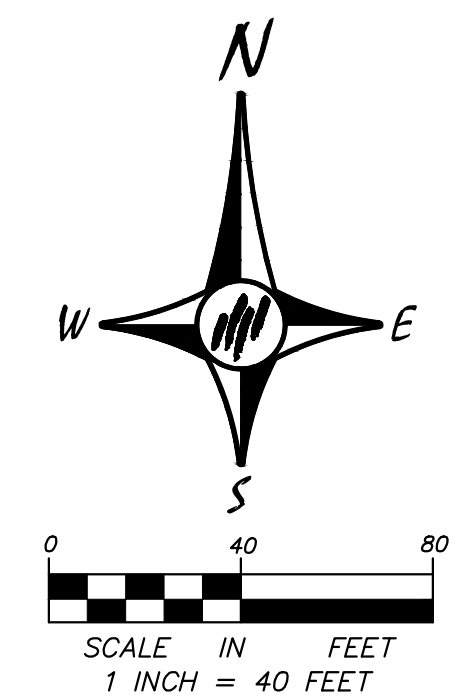
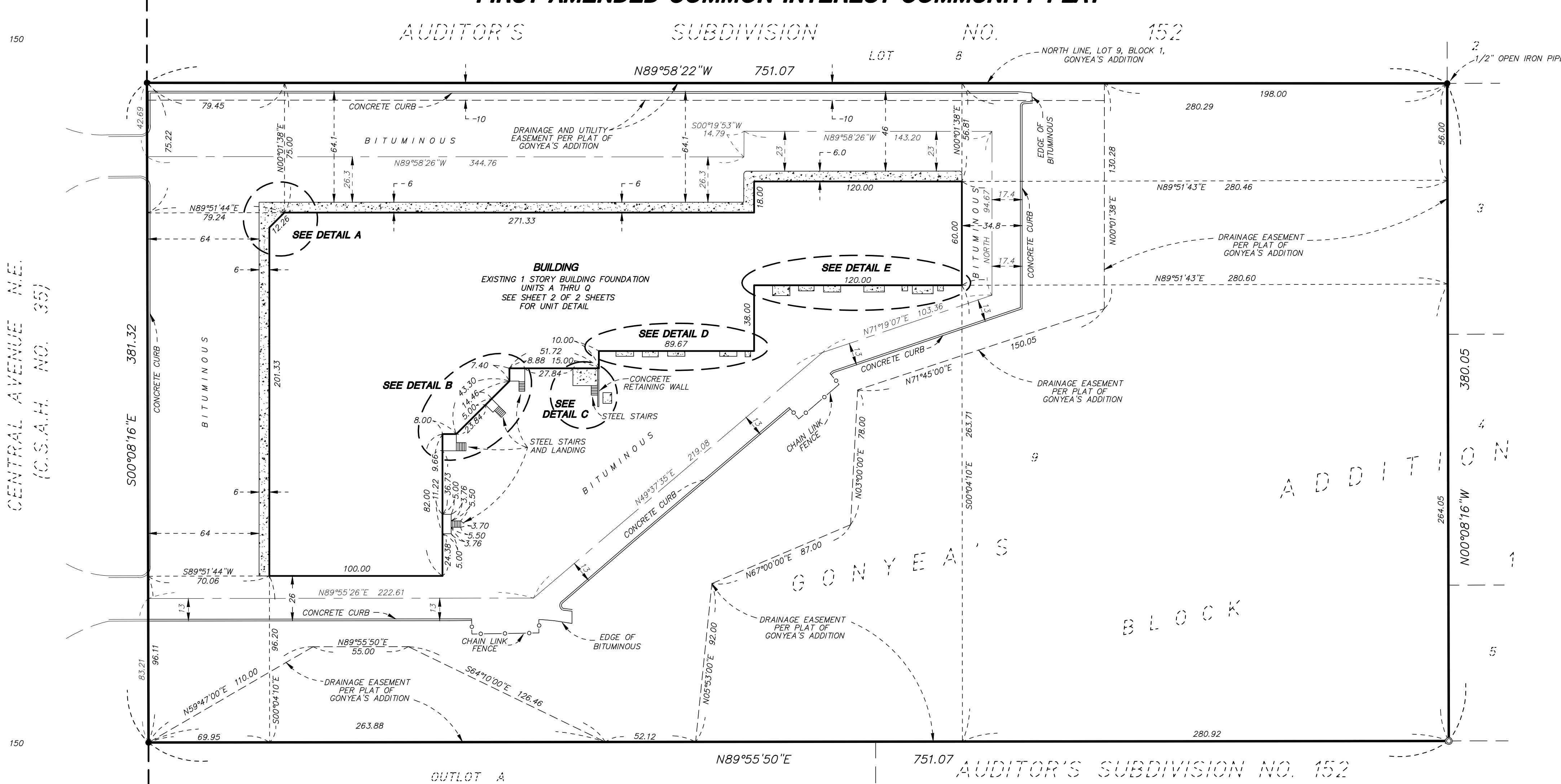

I, Kyle J. Roddy, do hereby certify that the work was undertaken by or reviewed and approved by me for this FIRST AMENDED CIC PLAT OF COMMON INTEREST COMMUNITY NUMBER 207, A CONDOMINIUM, SPRING LAKE PARK NUMBER TWO CONDOMINIUMS, being located upon:

Lot 9, Block 1, GONYEA'S ADDITION, Anoka County, Minnesota

And that this CIC plat fully and accurately depicts all information required by Minnesota Statutes, Section 515B.2-110(c).

Dated this _____ day of _____, 20____.

Kyle J. Roddy, Land Surveyor
 Minnesota License No. 42627

State of Minnesota
 County of _____

The foregoing instrument was acknowledged before me this _____ day of _____, 20____, by Kyle J. Roddy.

Notary Public, _____ County, Minnesota
 My commission expires _____

ANOKA COUNTY SURVEYOR

Pursuant to Minnesota Statutes, Chapter 389.09, Subd. 2, this CIC Plat has been reviewed and is approved this _____ day of _____, 20____.

By _____
 Larry D. Holm, Anoka County Surveyor

COUNTY AUDITOR/TREASURER

Pursuant to Minnesota Statutes, Section 505.021, Subd. 9, taxes payable in the year 20____ on the land hereinbefore described have been paid. Also, pursuant to Minnesota Statutes, Section 272.12, there are no delinquent taxes and transfer entered this _____ day of _____, 20____.

Property Tax Administrator

By _____ Deputy

COUNTY RECORDER/REGISTRAR OF TITLES

County of Anoka, State of Minnesota

I hereby certify that this SIXTH SUPPLEMENTAL CIC PLAT OF COMMON INTEREST COMMUNITY NUMBER 292, A CONDOMINIUM, GARAGE SOLUTION CONDOMINIUMS, was filed in the office of the County Recorder/Registrar of Titles for public record on this _____ day of _____, 20____, at _____ o'clock _____ M. and was duly recorded in Book _____ Page _____, as Document Number _____.

County Recorder/Registrar of Titles

By _____ Deputy

SITE PLAN

ALL IMPROVEMENTS EXTERIOR TO THE BUILDING ARE COMMON ELEMENTS UNLESS OTHERWISE SHOWN.

● DENOTES 1/2 INCH BY 14 INCH IRON PIPE MONUMENT SET AND MARKED BY LICENSE NO. 25287.

● DENOTES 1/2 INCH IRON PIPE MONUMENT FOUND AND MARKED BY LICENSE NO. 10943 UNLESS OTHERWISE NOTED.

■ DENOTES CONCRETE UNLESS OTHERWISE SHOWN.

FOR THE PURPOSES OF THIS PLAT, THE NORTH LINE OF LOT 9, BLOCK 1, GONYEA'S ADDITION HAS AN ASSUMED BEARING OF NORTH 89 DEGREES 58 MINUTES 22 SECONDS WEST.

BENCHMARK: TOP NUT OF HYDRANT LOCATED ON THE WEST SIDE OF CENTRAL AVENUE NORTH ±300 FEET NORTH OF THE INTERSECTION OF CENTRAL AVENUE NORTH AND 81ST AVENUE NE. ELEVATION = 908.28 (N.G.V.D. 1929)

ALL UNITS OF MEASURE ARE SHOWN IN FEET AND HUNDREDTHS OF A FOOT.

**COMMON INTEREST COMMUNITY NUMBER 207
 SPRING LAKE PARK NUMBER TWO CONDOMINIUMS
 A CONDOMINIUM
 FIRST AMENDED COMMON INTEREST COMMUNITY PLAT**

THIS FIRST AMENDED COMMON INTEREST COMMUNITY PLAT IS
 PART OF THE DECLARATION RECORDED AS DOCUMENT NO. _____
 ON THIS _____ DAY OF _____, 20____

**CITY OF SPRING LAKE PARK
 COUNTY OF ANOKA
 SEC. 1, T. 30, R. 24**

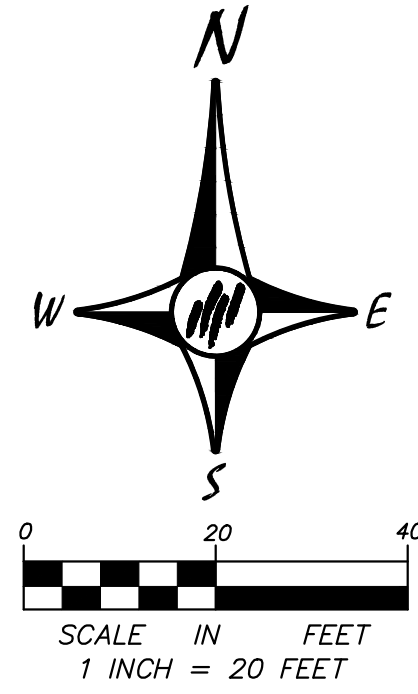

BUILDING FLOOR PLAN

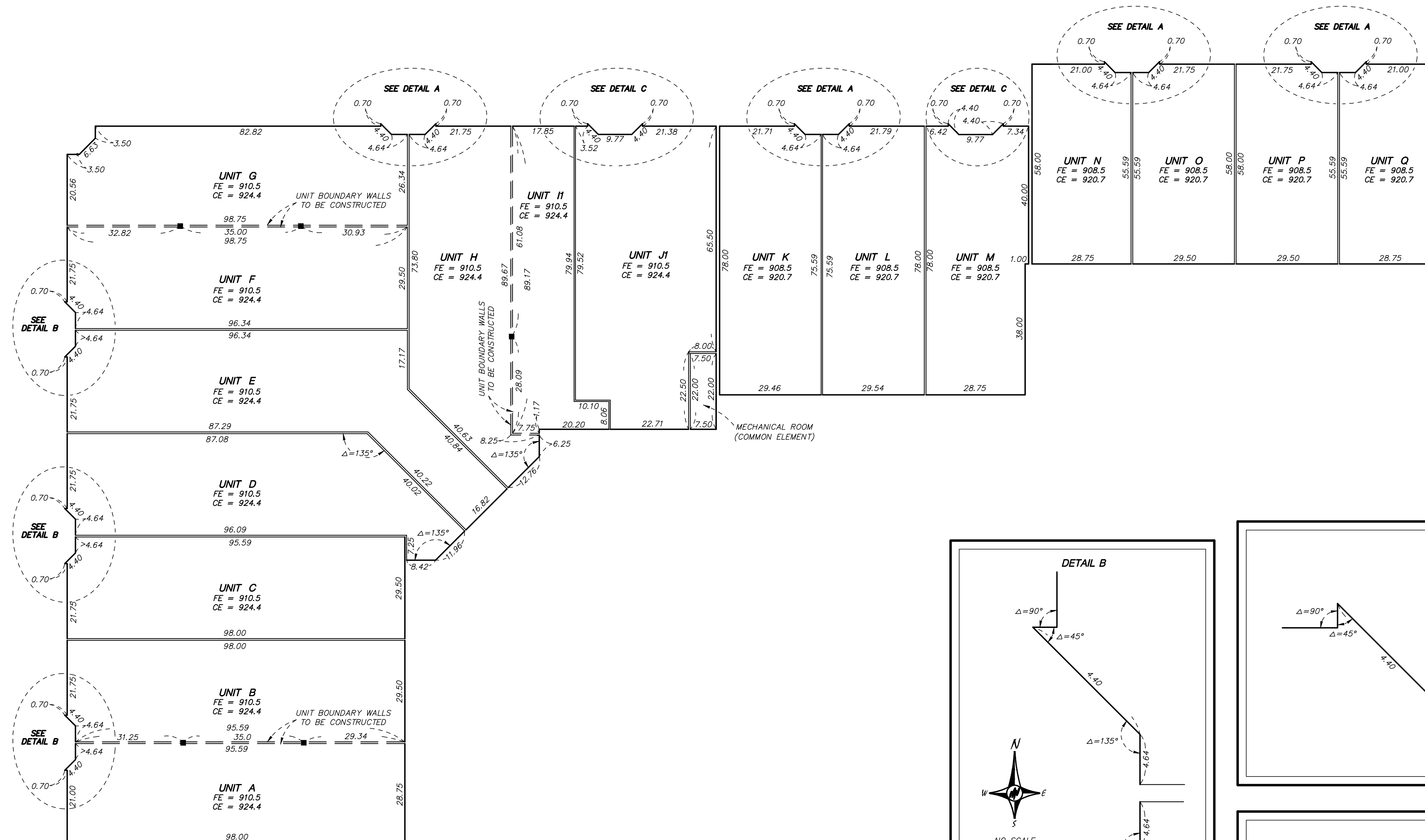

LEGEND

- CE = CEILING ELEVATION
- FE = FLOOR ELEVATION
- ELEVATIONS SHOWN ARE REFERENCED TO A BENCHMARK AS NOTED ON SHEET 1.
- ALL UNITS OF MEASURE ARE SHOWN IN FEET AND TENTHS OF A FOOT.
- DENOTES 0.6' BY 0.6' STEEL STRUCTURAL SUPPORT BEAM

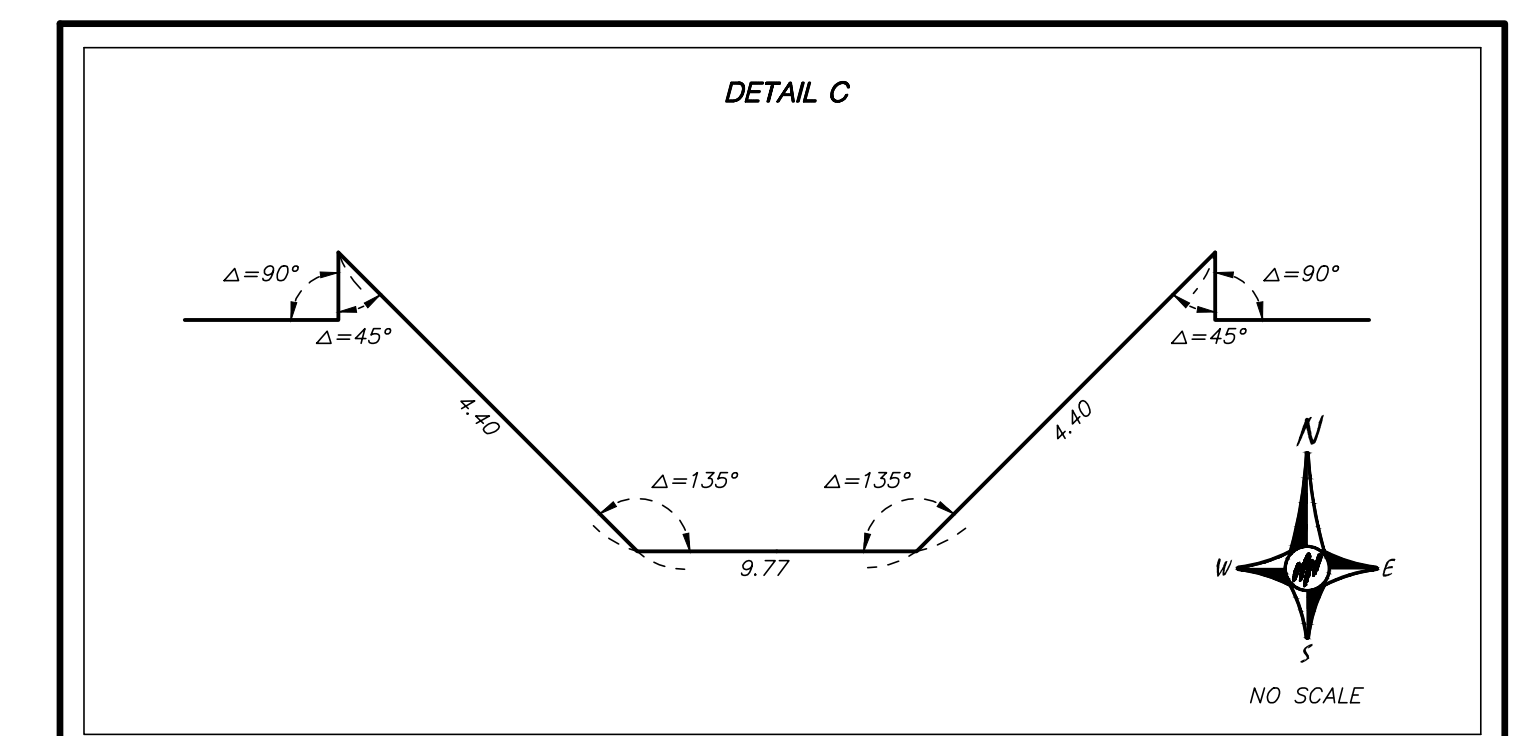
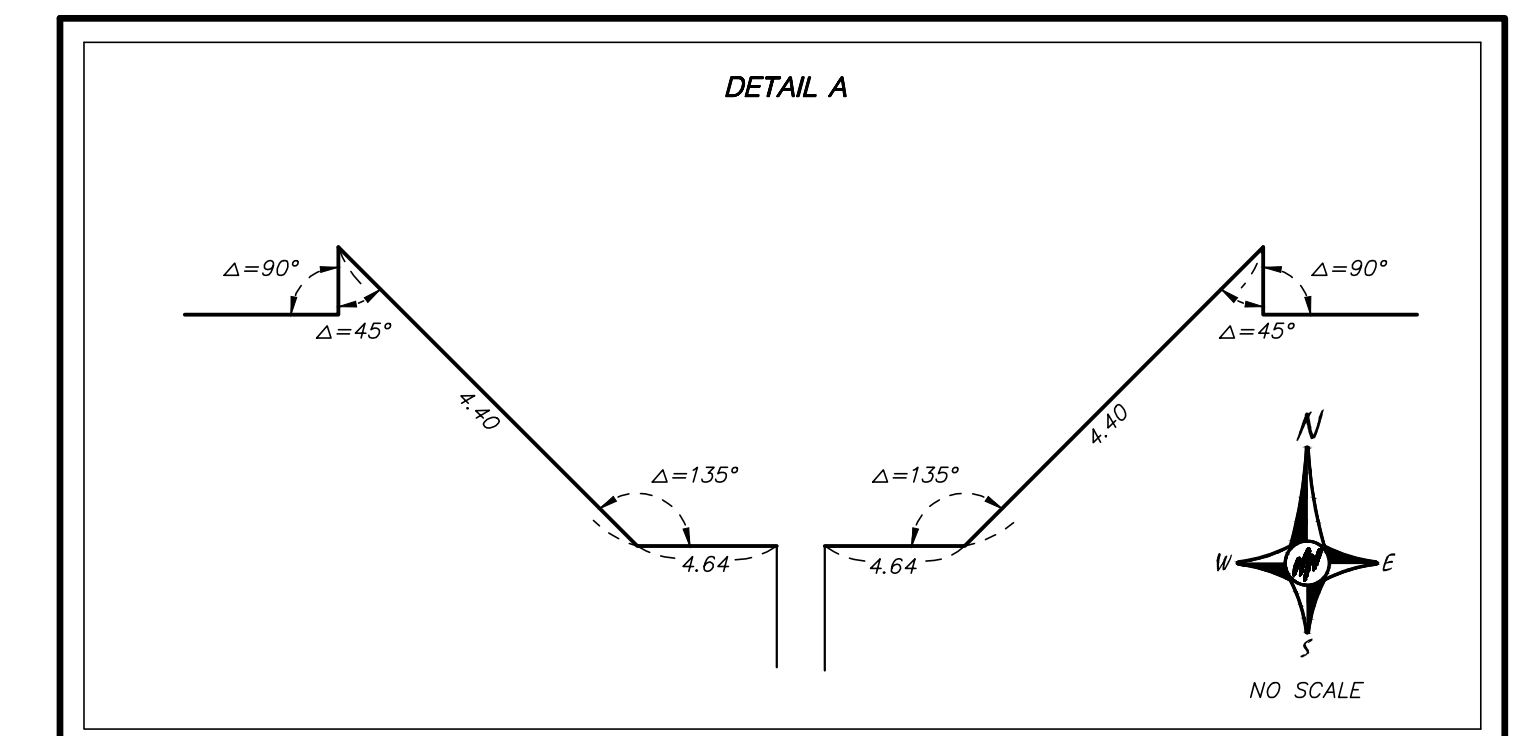
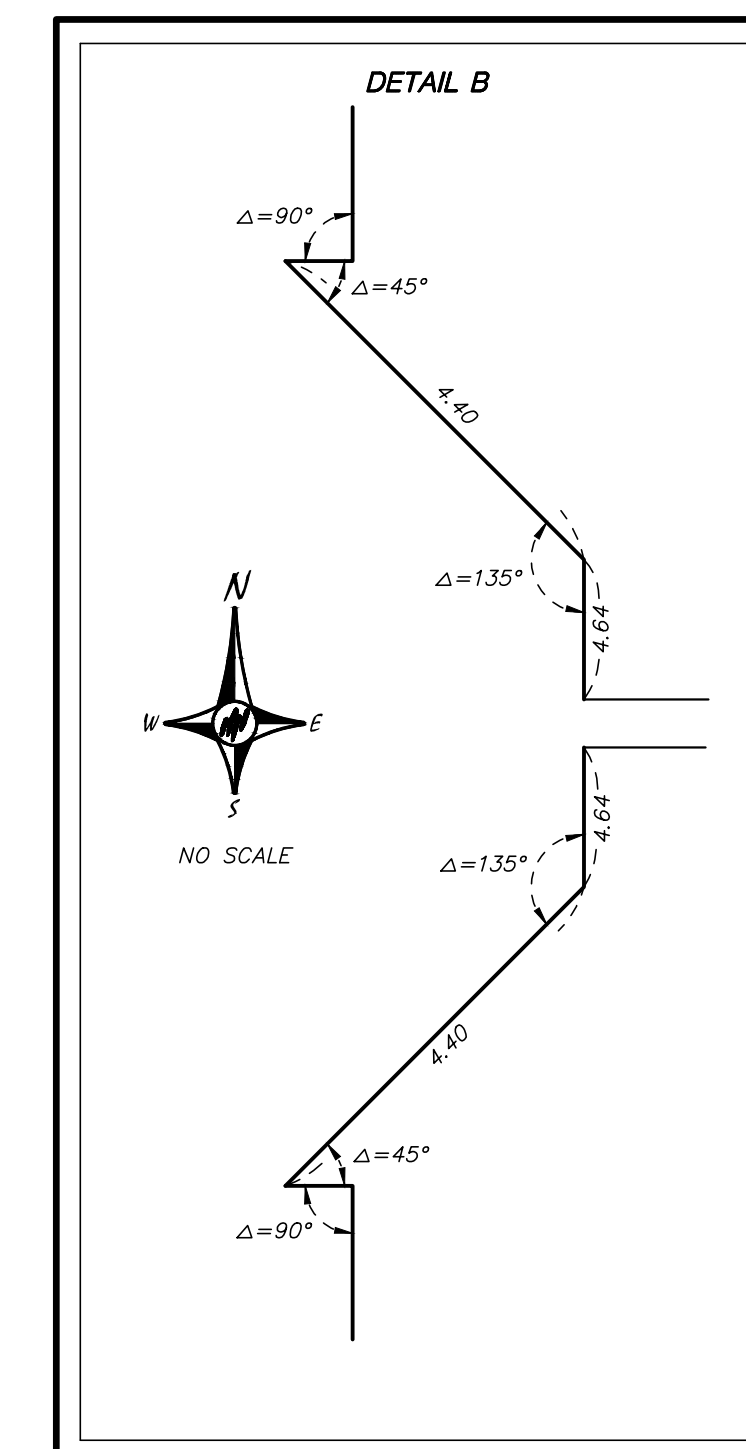

MEMORANDUM

TO: MAYOR HANSEN AND MEMBERS OF THE CITY COUNCIL
FROM: TERRY RANDALL, PUBLIC WORKS DIRECTOR
SUBJECT: AUTHORIZATION TO HIRE LEAD MAINTENANCE WORKER
DATE: APRIL 15, 2015

In March of 2015, the City was informed that Steve Coyle, Lead Maintenance Worker, was going to retire in April. The position was posted internally for candidates to apply. A total of three applications were received.

On April 7, 2015 interviews were conducted with the three applicants and it was determined that one candidate fit the requirements of the position very well. The applicant that was chosen as Lead Maintenance Worker is Brett Deboer. Brett has been with the City for 9 ½ years. I am recommending approval of Brett for the position of Lead Maintenance Worker.

If you have any questions, please do not hesitate to contact me at 763-784-6491.

MEMORANDUM

TO: MAYOR HANSEN AND MEMBERS OF THE CITY COUNCIL
FROM: DANIEL R. BUCHHOLTZ, CITY ADMINISTRATOR
SUBJECT: THIRD AMENDMENT TO SPRINT LEASE AGREEMENT
DATE: APRIL 7, 2015

The tower lease agreement between Sprint and the City originally adopted in 1999 has a provision for calculating inflationary adjustments to the lease payment at the start of each five year term. The current agreement states that “the rent shall be increased at the commencement of each renewal term by an amount equal to the five year increase in the Consumer Price Index (CPI) for the Minneapolis/St. Paul area as determined by the Minneapolis Library Department of Economics.” The problem with that language is that there is no Minneapolis Library Department of Economics in existence.

To determine the rate of inflation for the new term that started on January 1, 2015, staff used the CPI-U All Urban Consumers Semi-Annual Report as published by the U.S. Department of Labor Bureau of Labor Statistics for Minneapolis-St. Paul. Sprint has agreed to use this report to determine the five year inflation rate for each new term.

The Third Amendment to the Sprint Tower Lease Agreement makes this change. It also updates the notice addresses as well. This is timely as the notice addresses in the existing agreement are no longer correct (we had notices returned to us recently).

City Attorney Carson has reviewed the proposed agreement and has recommended no changes. Staff recommends approval of the lease agreement.

If you have any questions regarding the proposed tower lease amendment, please don't hesitate to contact me at 763-784-6491.

THIRD AMENDMENT TO TOWER LEASE AGREEMENT

This Third Amendment to Site Agreement (“**Third Amendment**”), effective as of the date last signed below (“Effective Date”), amends a certain Site Agreement between Sprint Spectrum Realty Company, L.P., a Delaware (“**Sprint**”), successor in interest to Sprint Spectrum, L.P. a Delaware limited partnership and City of Spring Lake Park, Minnesota (“**Owner**”), dated November 15, 1999 as amended by the First Amendment to Site Agreement (“**First Amendment**”) dated September 19, 2005 and the Second Amendment to Tower Lease Agreement (“**Second Amendment**”) dated November 17, 2014 (the Lease, First Amendment and Second Amendment are collectively, the “**Agreement**”).

BACKGROUND

Owner and Tenant desire to amend and modify provisions of the Agreement with regards to the rental payments and increases paid by Tenant to Owner.

AGREEMENT

In consideration of the mutual promises between the parties and for other good and valuable consideration the receipt and sufficiency of which is acknowledged, Owner and Sprint agree as follows:

- 1. Rent:** Paragraph 3.b of the Agreement is deleted in its entirety and replaced with the following: “The rent shall be increased at the commencement of each renewal term by an amount equal to the change in the Consumer Price Index (CPI) for the index for CPI-U All Urban Consumers, 1982-84=100 Minneapolis, St. Paul Semi-Annual published report, area as published by the United States Department of Labor Bureau of Labor Statistics as follows: Rent payable for each renewal term following the initial term shall be determined by multiplying the rent payable during the preceding initial term or renewal term, as the case may be, by the sum of: (i) one, plus (ii) the percentage increase in the CPI during the preceding initial term or renewal term as the case may be. If the CPI shall be discontinued, then Owner and Sprint shall mutually agree upon either another standard recognized cost of living index issued by the United States Government or a fixed percentage increase.”
- 2. Notice Address.** The notice addresses in Section 20 of the Agreement or referenced therein for the party or parties listed below are hereby deleted in their entirety and replaced with the following:

To Owner: City of Spring Lake Park
Attn: Administrator, Clerk/Treasurer
1301 81st Avenue NE
Spring Lake Park, MN 55432

To Sprint: Sprint Property Services
Sprint Site ID: **MS14XC851-A**
Mailstop KSOPHT0101-Z2650
6391 Sprint Parkway
Overland Park, Kansas 66251-2650

With a mandatory copy to: Sprint Law Department
Sprint Site ID: **MS14XC851-A**
Mailstop KSOPHT0101-Z2020
6391 Sprint Parkway
Overland Park, Kansas 66251-2020
Attn.: Real Estate Attorney

3. General Terms and Conditions.

(a) All capitalized terms used in this Amendment, unless otherwise defined herein, will have the same meaning as the terms contained in the Agreement.

(b) In case of any inconsistencies between the terms and conditions contained in the Agreement and the terms and conditions contained in this Amendment, the terms and conditions herein will control. Except as set forth herein, all provisions of the Agreement are ratified and remain unchanged and in full force and effect.

(c) This Amendment may be executed in duplicate counterparts, each of which will be deemed an original.

(d) Each of the parties represent and warrant that they have the right, power, legal capacity and authority to enter into and perform their respective obligations under this Amendment.

The parties have executed this Amendment as of the Effective Date.

Owner:
City of Spring Lake Park, Minnesota

Sprint:
Sprint Spectrum Realty Company, L.P.,
a Delaware limited partnership

By: _____

By: _____

Name: _____

Name: _____

Title: _____

Title: _____

Date: _____

Date: _____



City of Spring Lake Park

Engineer's Project Status Report

To: Council Members and Staff

Re: **Status Report for 4.20.15 Meeting**

From: Phil Gravel *PG*

File No.: R-18GEN

Note: Updated information is shown in *italics*.

2015 Sanitary Sewer Lining Project (193803135).

This project includes lining and wye grouting in the northeast corner of the city. Bids will be received on May 11, 2015 at 1:15 PM. Bid results will be presented at the May 18th Council Meeting.

2015 Seal Coat Project (193803134).

Construction Contracts have been sent to the low bidder (Pearson Bros.). A Seal Coat map has been posted on the city website.

2014-2015 Street Improvement Project (193801577).

Construction is scheduled to start on 81st Avenue west of Monroe on April 20th. Property owner notices have been delivered (copy attached).

Work on Arthur Street, TH 65 Service Drive, and 81st Avenue east of Monroe will follow.

CSAH 35 Turn Lanes and Sidewalk (193802914).

This project includes CSAH 35 improvements required as part of the SUP for 8299 Central Ave. A Feasibility Report outlining the necessary improvements and providing estimated costs has been prepared. Plan and Spec preparation is in process.

MS4 Permit (193802936).

Remaining permit implementation items from 2014 have been completed.

Lift Station No. 1 Equipment (193802805).

Bids for the lift station equipment were approved on January 5th (3 quote packages).

Lift Station No. 1 Reconstruction (193803115).

Plan approval is scheduled for April 6th (see separate letter). Bids will be received on May 11, 2015 at 1:00 PM. Bid results will be presented at the May 18th Council Meeting.

Medical Building at 525 Osborn.

The developers have indicated that this project is on long-term hold. We understand that they are currently working on issues with Anoka County.

Other issues/projects.

We continue to work with T-Mobile and Sprint on their applications for antenna modifications. A preconstruction conference with Sprint has been held.

Feel free to contact Harlan Olson, Cristina Mlejnek, Phil Carlson, Jim Engfer, Mark Rolfs, Tim Grinstead, Tyler Johnson, or me if you have any questions or require any additional information.



City of Spring Lake Park
2014-2015 Street Improvement Project



City of Spring Lake Park

Construction Update

April 16, 2015

81st Avenue West of Monroe

81st Avenue is scheduled to be completed in two phases: west of Monroe Avenue and east of Monroe Avenue. **West of Monroe is scheduled to start next week;** and, east of Monroe is scheduled to start during the first week of May.

Tentative schedule (weather permitting):

Monday, April 20 th	Prep work – set up signage, catch basin inlet protection, Begin removing bituminous pavement
Tuesday, April 21 st	Signal loop work at University Avenue, begin concrete removals
Week of April 27 th	Remove manhole castings; pour concrete curb/gutter, aprons and sidewalk; start grading/compacting rock base
Week of May 4 th	pave the first two layers of pavement; clean up; adjust structures in the street; restorations.

The final layer of pavement is scheduled to be paved later in the season.

Please call any of the people below with any scheduling or construction-related items.

Project Contacts.

- o Feel free to contact any of the following people throughout the project process if you have any questions:

Cristina Mlejnek, Project Engineer (651) 967-4619 cristina.mlejnek@stantec.com	Terry Randall, Public Works Director (763) 792-7227 trandall@slpmn.org
Phil Gravel, City Engineer (651) 604-4803 phil.gravel@stantec.com	Dan Buchholtz, City Administrator (763) 792-7211 dbuchholtz@slpmn.org

MEMORANDUM

April 15, 2015

TO: Mayor and City Council
FROM: Wanda Brown, Recycling Coordinator
RE: Spring 2015 Recycling Day Information

The Spring Recycling Day will be held on Saturday, April 25, between 9:00 AM-1:00 PM. Residents should have received a postcard in the mail about the event. It is important that the residents bring the postcard with them along with a photo id. Information about the event was placed in the Blaine-Spring Lake Park Life, on the cable television channel 16, on the City Community Billboard, and it can be found on the city website www.slpmn.org.

If you or any of the residents have questions please call Monday-Friday from 8 am – 4:30 pm, at 763-792-7219. Thank you for your continued support of the recycling program.

CORRESPONDENCE

MCGRANN
SHEA
CARNIVAL
STRAUGHN
& LAMB
CHARTERED

CAPITOL UPDATE REPORT

From: Sarah J. Psick
Date: April 10, 2015
Re: Capitol Update Report

Liquor Issues Update

Sunday Sales: On Wednesday, the House Commerce and Regulatory Reform committee held an informational hearing on two bills related to Sunday sales – one to repeal the prohibition for sales on Sundays, the other to allow municipalities to vote on whether to allow liquor stores to open on Sunday or not.

Testifying in support of Sunday sales were the following: Rep. Jenifer Loon (R, Eden Prairie) chief author of the bills; Andrew Schmitt with the Minnesota Beer Activists, DISCUS, Albertville City Council member and Republican Liberty Caucus, liquor store owners or workers – Louis Dachis with Ace Spirits, Jason Alvey with Four Firkins, Dave Erickson with Tower liquor store and bar, J.M. Companies, and a few others.

Many MLBA and MMBA members were present in the audience, along with members of the Teamsters and Minnesota Beer Wholesalers Association, in opposition to the bills. Testifying in opposition were:

- Kim Wilson, Oaks Wine and Spirits in Stillwater, Minn.
- Terry Furlong, Furlong's Liquor in Oakdale, Minn.
- Steve Burwell, Fairview Wine & Spirits in Roseville, Minn.
- Mike Hansen, Ham Lake Liquors in Ham Lake, Minn.
- Ed Reynoso, Teamsters Joint Council 32
- Scott Neal, City Manager, City of Edina

The committee discussion was very good, with many members expressing support of the current law. If you are interested, you may watch the House Public Information Office video of the committee hearing at this link:

http://www.house.leg.state.mn.us/htv/archivesCOMM.asp?comm=89006&ls_year=89

Minimum Wage and Other Issues: The House Job Growth and Energy Affordability Policy and Finance division included several minimum wage related issues in the committee's omnibus budget bill.

- Two-tiered wage, tip recognition (previously passed on the House Floor)
- Credit card Gratuities (provides that the full amount of a gratuity paid through a credit card must be paid to the employee)
- Uniform State Minimum Wage (prohibits a local government from setting a minimum wage higher than the state minimum wage, with certain exceptions.)
- Uniformity of private (prohibits a local government from setting private employer benefits relating to benefits, terms of employment, working conditions, attendance or leave policies that exceed state or federal requirements.

The omnibus budget bill will be passed out of the House Jobs committee later today and will move through a few more committees before being considered on the House Floor. The Senate has not yet assembled a companion omnibus budget bill. Many of these issues will be negotiated through an end-of-session conference committee.

General Legislative Update

State of the State: Last night, Governor Dayton delivered his fifth State of the State address to a joint convention of the Minnesota House and Senate. He started his address by saying, "The state of our state is good. Not everywhere. Not for everyone. But overall, Minnesota is doing better than it has for some time, and Minnesota is doing better than most other states." Governor Dayton said that his top priorities for this session are "everything," including closing the achievement gap, buffer zones for better water quality and habitat, tougher penalties for poachers, increased funding for the judicial branch, completion of the Lewis & Clark water project; final Capitol restoration, funding for broadband, and "all the rest." However, at the top of his priorities are education and transportation. The Governor has recommended spending an additional \$694.6 million for education, including an initiative to fund pre-kindergarten classes for the state's four-year-olds. The Governor complimented both the House and Senate for recognizing the importance of transportation funding this session. However, he stressed that they still need to find agreement on the amounts of the investments and how to assure they will continue reliably over the next decade. The Governor cautioned against reallocating general fund dollars to pay for transportation – one of the key components of the House Republican transportation funding proposal. The Governor also urged passage of a significant bonding bill this session. Republican Speaker of the House, Kurt Daudt, responded to the Governor's remarks by saying that the state of the state is improving, but it is a cautious recovery and they want to be cautious with the surplus and spending.

Governor's Bonding Bill: Earlier this week, Governor Dayton presented an \$842 million bonding bill called, "Governor Dayton's 2015 Minnesota Jobs Proposal." The Governor said the bill will put up to 23,900 Minnesotans back to work by making investments in MnSCU and University of Minnesota buildings and classrooms, improving local parks, roads and infrastructure across the state. The proposal also includes investments in flood repair, historic preservation, housing, Capitol renovation, and rail safety improvements. The Governor distributed a map of the state demonstrating that projects in the proposed bonding bill reach all parts of the state - from a new fire hall in Hallock and DNR flood mitigation in Roseau; to investments in the Lewis & Clark regional water system in Worthington; to the 1868 Lanesboro Stone Dam repair in Lanesboro; to repairs and improvements to the veterans home in Silver Bay; and, to renovation of the Fort Snelling visitors center in the metropolitan area. The bill was met with a cool reception in the Legislature. Minnesota's constitution requires all bonding bills to originate in the House of Representatives. To date, the House Republican majority has stated they will wait until next year, a traditional bonding year, for passage of a major bonding bill.

Free College Tuition: SF 2 would provide free tuition for two-years of college in the MnSCU system with the goal of filling a shortage of skilled labor in the state. Sen. LeRoy Stumpf (DFL, Plummer), chair of the Senate bonding committee, stated that last year when the bonding committee was touring the state to look at projects, one thing they heard in almost community was a lack of a skilled workforce. The bill is trying to encourage high school graduates, or those with alternative degrees and certificates to enter this grant program and become skilled workers. The chief author of the bill also hopes to encourage more diverse populations of students to enter the higher education system. The bill was heard in the Senate Higher Education Finance committee this week and laid over for possible inclusion in the omnibus higher education finance bill.

Omnibus Budget Bills: The House and Senate began rolling out omnibus budget bills this week. In the Senate, the State Departments and Veterans budget bill was released; and in the House, the Job Growth and Energy Affordability Policy and Finance, as well as, the Transportation Policy and Finance committees also released omnibus budget bills. The bills were presented in the committees, public testimony is being taken and over the next few days the bills will be amended and voted out of committee. Before the third committee deadline of April 24, nine more budget bills will be released in the House and six more budget bills will be released in the Senate (the Senate omnibus transportation finance bill was released prior to the legislative break.)

Next Week: We can expect to spend long days and nights in the House and Senate committees as the process of assembling omnibus budget bills continues.

Daniel Buchholtz

From: Jung, Paul (DOT) <paul.jung@state.mn.us>
Sent: Monday, April 13, 2015 4:21 PM
To: dbuchholtz@slpmn.org; trandall@slpmn.org; Phil.Gravel@stantec.com; JKeely@ci.blaine.mn.us
Subject: FW: Highway 65 repaving, 53rd Ave. to Moore Lake Dr., first weekend of May 2015

Below is an announcement I sent to Fridley, Columbia Heights, and Anoka County about repaving of Highway 65 between **53rd Avenue and Moore Lake Drive**.

Although the work zone is south of Spring Lake Park and Blaine, I also wanted you to be aware of it, in case your city staff or citizens may notice the work that weekend.

Paul

A key task remaining from last year's Highway 65 resurfacing and safety improvement project is to mill and overlay Highway 65 between 53rd Avenue and Moore Lake Drive.

We expect this mill and overlay will be completed in just one weekend of intensive work.

The work is scheduled to **begin the evening of Friday, May 1, and be completed before morning rush hour on Monday, May 4**. These dates are tentative. In the event of rain, the work will be postponed until a future weekend. We will avoid working the weekend of Fishing Opener or Memorial weekend.

During the weekend of intensive work, expect lane closures and delays in both directions of Highway 65 between 53rd Avenue and Moore Lake Drive. There will also be periodic ramp closures at the Highway 65–I-694 interchange.

For folks with destinations near the project area, I recommend that during the project they consider approaching from University Avenue or from Silver Lake Road, to avoid the work zone.

Thank you for your patience and cooperation as we wrap up the project.

Paul

Paul Jung, P.E., PTOE
North Area Engineer
Minnesota Department of Transportation, Metro District
(651) 234-7716

From: [Becca Pryse](#)
To: [Becca Pryse](#)
Subject: NMMA Legislative Update - April 10, 2015
Date: Friday, April 10, 2015 4:18:09 PM
Importance: High

North Metro Mayors Association
Legislative Update
April 10, 2015

Happenings at the Capitol

It was a busy week for legislators in the House and Senate as both bodies focus on assembling their budgets before the third committee deadline of Friday, April 24. As the Legislature continues to work toward the constitutionally imposed adjournment date of Monday, May 18, please be reminded that our legislative relations team is here to assist you.

State of the State Address

Gov. Dayton gave his State of the State speech on Thursday to a joint session of the House and Senate. The State of the State address is typically an opportunity for the governor to set the agenda for the legislative session, but since the end of session is only five weeks away that wasn't as much of a factor for this year's speech. Many of the positions Gov. Dayton laid out were already well known but it provided him with an opportunity to pressure lawmakers into acting on his proposals.

Dayton said his top two priorities for this session are improving and investing in education and the transportation system in our state. Dayton specifically drew attention to transportation which he called his, "second top priority for this legislative session," saying his \$11 billion, 10 year transportation spending plan would assist the state in catching up on increasing needs caused by increasing populations and aging infrastructure.

If you missed it, you can view the Governor's address here:

[http://www.house.leg.state.mn.us/htv/programa.asp?
ls_year=89&session_year=2015&session_number=0&event_id=881994](http://www.house.leg.state.mn.us/htv/programa.asp?ls_year=89&session_year=2015&session_number=0&event_id=881994)

Transportation

The House Transportation Bill was released this week with committee mark-up expected to be done next week. The House bill prioritizes funding roads and bridges over transit utilizing existing state revenues. With the House, Senate and Governor all acknowledging a significant

increase is needed in transportation funding over the next 10 years, it will be interesting to watch how an agreement on transportation funding will be reached. The [delete-all amendment](#) to [HF 4](#) can be found here.

The Senate Transportation and Public Safety Budget Division heard presentations on project-specific bonding bills, several of which are important to NMMA. The committee did not act on any bills but will consider them for possible recommendation to the Senate Capitol Investment Committee. Thank you to our NMMA legislative delegation and local testifiers for their work this week. The Division heard the following bills:

[SF0648](#) (Hoffman) – Coon Rapids U.S. highway 10 third lane addition

[SF0044](#) (Hoffman) – Coon Rapids/Hanson Boulevard highway-rail grade crossing

[SF0956](#) (Petersen) - Anoka and Ramsey U.S. highway 10 improvements

[SF1666](#) (Petersen) - Anoka County U.S. highway 10 improvements

[SF1991](#) (Petersen) – Ramsey highway-rail grade separation project

[SF0493](#) (Rest) - Bottineau light rail transit (LRT) bond issue and appropriation, [Bottineau Line information sheet \(PDF\)](#)

[SF0885](#) (Rest) - Crystal highway-rail grade separation construction bond issue and appropriation, [Crystal crossing map \(PDF\)](#) and [Crystal crossing information sheet \(PDF\)](#)

[SF0882](#) (Rest) - Plymouth highway-rail grade separation construction bond issue and appropriation (Vicksburg Lane)

Legislation authored by Senator Anne Rest and Representative Sarah Anderson limiting railroad condemnation powers continues to make their way through the legislative process.

[SF1251](#) (Rest) and [HF1467](#) (Anderson, S.) await possible floor debate and votes on both the Senate and House floors. Read a recent Sun Post article here:

<http://post.mnsun.com/2015/04/legislation-that-limits-railroads- eminent-domain-nears-floor-votes/>

Local Government Aid

The House Property Tax & Local Government Finance Division spent significant time this week debating the Local Government Aid program when [HF2034](#) (Quam) received a hearing. The bill proposes that, beginning with aids payable in 2015, the bill limits the per capita LGA payments to cities of the first class to the average per capita aid paid to all other cities in the state. The reduction in aid to these cities will be retained in the general fund. The bill was met with resistance by the four first class cities, as well as, by other groups who, like NMMA, support the current formulas and advocate for no change. The bill was laid over for possible inclusion in an omnibus bill produced by the Division.

Legislative Delegation Individual Meetings

Bob Benke and Troy Olsen continue to schedule meetings with members of the NMMA legislative delegation to discuss the NMMA Legislative Action Plan. At the meetings, Bob provides a wealth of data and background information supporting the positive results of

recent changes in the LGA and Fiscal Disparities programs while highlighting the NMMA position that the formulas should not be revised. Legislators also are briefed on NMMA's transportation system funding priorities and offered assistance from NMMA should they need additional support on these items. Bob and Troy have individually met with 18 NMMA delegation members and will continue to schedule meetings for the remainder of the legislative session.

Governor Dayton Releases Bonding Bill

On Tuesday, Gov. Dayton introduced his \$842 million bonding proposal that will invest in [projects across the state](#). Highlights of his proposal include \$200 million for improvements to MnSCU and University of Minnesota facilities, as well as, \$169 million for statewide economic development.

The bill faces considerable obstacles in order to be passed this year. Typically large bonding proposals are done in the second year of the biennium, while finalizing the state budget remains the focus of the legislature for the first year. Speaker of the House Kurt Daudt (R-Crown) said earlier this year that there was little support in his caucus for a bonding bill this session, but this week he indicated he wouldn't close the door on the idea of passing a small bonding bill in anticipation of a larger one next session. Senate Majority Leader Tom Bakk (DFL-Cook) has said he supports passing a small bonding bill this year; however, it is required that a bonding bill be initiated by the House of Representatives, so for any immediate action House Republicans will have to take the first step in moving a bill forward.

If you have any questions, or if your city has legislation or an issue that we are not aware of, please contact us.

Becca Pryse
beccap@ewald.com
612-490-2651

Bob Benke
bobbenke@comcast.net
612-669-0274

Bill Barnhardt
wbarnha@gmail.com
612-702-4931

Jill Brown
jillcbrown@msn.com
612-889-2611

Troy Olsen
troyo@ewald.com
763-381-7894



**NOTICE OF PUBLIC HEARING on
Urban Stormwater Remediation Cost-Share Requests
from Cities of Arden Hills, Columbia Heights,
Fridley, Roseville, and White Bear Township**

PLEASE TAKE NOTICE that at its **regular board meeting on Wednesday, April 22, 2015 at 9:00 a.m.** in the Shoreview City Council Chambers, 4600 North Victoria Street, Shoreview, Minnesota, the Rice Creek Watershed District (RCWD) Board of Managers will receive public comment under Minnesota Statutes 103B.251 on the ordering of one or more of the following projects: City of Arden Hills – 2015 Pavement Management Program, City of Columbia Heights – Silver Lake Boat Landing Stormwater Retrofits, City of Fridley – Village Green Stormwater Detention Expansion, City of Roseville – Evergreen Park Underground Storage & Reuse System, White Bear Township – Barry Lane Detention Pond Restoration. The RCWD's share of cost for each funded project will not exceed \$50,000 and would be funded by general tax levy on real property within the watershed. The cost-share requests can be reviewed at www.ricecreek.org or at the District office.

Rice Creek Watershed District
4325 Pheasant Ridge Dr., #611
Blaine, MN 55449-4539
763-398-3070